



H&F Maintenance

Repairs and Maintenance Handbook



Repairs and Maintenance Handbook

Contents

Introduction	4
Introduction	4

How to report a repair	5
Different ways to report a repair and what to call us for	5
Estate services and pest control	6

Landlords	7
Our overall responsibilities as a landlord	7-10
Damp and condensation What is condensation?	11-13

Leaseholders	14
How this book applies to leaseholders	14
Leasehold repair responsibilities	15-16

Repairs picture finder and how to use it	17
Repairs picture finder	18-49
Gas safety	40

More about repairs...	50
Discretionary support for repairs	51-52
Sheltered residents' handy-person service	53
What we need from you to help us	54
Respect, security and identification	55-57
How we prioritise and chargeable repairs	58
Priority and targeted completion times	59
Emergency repairs	61
Repairs on defects / planned works	62
Common questions	63-65

H&F approach to repairs and maintenance	66
Planned programmes	67
Misuse, damage or neglect	68
Accidental damage	69

Your health and safety	70
What we're doing to keep you safe: Gas safety	71
What we're doing to keep you safe: Carbon Monoxide	72
What we're doing to keep you safe: Fire safety	73-74
What we're doing to keep you safe: Electricity	75
What we're doing to keep you safe: Lifts and estate inspections	76
What we're doing to keep you safe: Water assessment	77
What we're doing to keep you safe: Asbestos	78

Maintaining the structure and environment	80
Improvements	81

Information	82
Useful contacts	82-83
Index	84

Get Involved	85
---------------------	-----------

Ways to report a repair	86
--------------------------------	-----------

H&F repairs and maintenance handbook

Introduction



Welcome to our H&F Maintenance handbook.

The council worked with residents on producing this handbook, to help you report repairs easily and effectively and to provide you with additional information on the maintenance and health and safety work that we regularly carry out.

Our staff are committed to providing you with a fast, polite and efficient service when you contact us and, equally, we expect all our contractors to be polite and respectful at all times when working in and around your home.

We hope you will find this handbook useful and informative.

How to report a repair

Different ways to report a repair and what to call us for

- ✔ Repairs to tenanted properties and communal areas

- ✔ Out of hours emergency make safe repairs to tenanted properties and communal areas

- ✔ White goods such as laundry equipment in sheltered schemes but only where the council has provided them

- ✔ Communal TV aerials supplied by the council

Ways to report a repair:

Freephone: 0800 023 4499

Email: Housing.Repairs@lbhf.gov.uk

Online: www.lbhf.gov.uk/housing/council-tenants/reporting-repairs/housing-repairs-notification-form

Staff at our housing offices will be able to help you report your repair to the Customer Service Centre.

Hammersmith

New Zealand Way, White City W12 7DE

Fulham

363 North End Road, SW6 1NW

Both are open:

Monday to Friday, 9am to 5pm

When reporting a repair, you'll be given a job number, an appointment or a targeted completion date.

How to report a repair

Estate services and pest control



Call Estate Services on **020 8753 5646** or email **ESRequest@lbhf.gov.uk** for all caretaking issues, grounds maintenance and for all of the following:

- Blocked bin chutes
- Trees in communal areas but only if the tree is on an estate
- Fly tipping on estates
- Playground equipment.

Pest control: If you have a problem in your home contact the team **020 8753 1081** or email them at **environmentalprotection@lbhf.gov.uk** for help and advice.

Landlord

Our overall responsibilities as a landlord

As a landlord we need to ensure we keep the property in a good state of repair. Individual tenancy and leasehold agreements set out the contractual repair and maintenance responsibilities for H&F and our customers. In summary as a landlord H&F will maintain it's buildings in a good state of repair. some examples of common landlord responsibilities are given in the table below:

Area	Types of work
Structure and key components of the building and exterior of property	<p>We are responsible for keeping in repair the structure and exterior of a customer's home and the building in which it is situated. This includes:</p> <ul style="list-style-type: none">• Roofs• Chimneys• Floor joists• Internal stairs and balustrades• Doors and windows• Walls and plaster• Paths• External steps, ramps, balconies, canopies• Fire stops and compartmentalisation of buildings

Landlord

Our overall responsibilities as a landlord

Area	Types of work
Gas, water and electricity	<p>We are responsible for keeping in repair and working order installations for the supply of water, gas and electricity.</p> <p>This includes:</p> <ul style="list-style-type: none">• Electrical and gas installations - heating and hot water - gas appliances*, pipes, flues and ventilation, electrical wiring, lighting, distribution board, residual current devices (circuit breakers), fire, smoke, heat and CO alarms to individual properties.• Water hygiene, sanitary fittings - basins, sinks, baths, showers and taps, including water pipes, drains, soil stack and gutters. Drainage and sewage systems. We are responsible for repairing all leaks to our pipe work. <p>*Not appliances owned by the resident.</p>

Area	Types of work
<p>Managing hazards that may present a risk to health</p>	<p>We have an obligation to manage hazards that could present a risk to health for the resident or a member of their household. This could include:</p> <ul style="list-style-type: none"> • Promoting property security through well-fitting doors and windows and locks • Damp and mould management* • Prevention of injury from glazing • Management of asbestos and other Manufactured Mineral Fibres • Managing holes and gaps to help prevent pest or insect infestations • Sealed and water tight joints around sanitary fittings, cupboards, work surfaces • Provision of fire doors (this includes surround, locks, closers, hinges and door furniture to maintain warranties).
	<p>*Where this relates to an issue with the structure of the building</p>

Landlord

Our overall responsibilities as a landlord

Area	Types of work
Communal areas	<p>We will ensure that the communal areas are kept in reasonable repair, and are fit for use.</p> <p>This includes maintaining all entrances, halls, lifts, stairways, passageways, refuse chutes, lighting, door entry systems, ramps, communal areas and other parts provided for common use.</p> <p>Ensuring that, where provided, fire protection systems and fire fighting equipment is adequate, regularly inspected and serviced.</p>

Damp and condensation



What is condensation?

Condensation is the most common form of damp. It appears when excess moisture in the air comes into contact with a cold surface, such as a window or a cold wall. There is always some moisture in the air, even if you cannot see it. If the air gets colder, it cannot hold all the moisture and tiny drops of water appear.

Additional moisture is created by:

- Cooking or boiling water;
- Taking baths or showers;
- Drying clothes indoors.

Damp and condensation

What you can do to reduce any condensation?

1 Produce less moisture:

Some ordinary daily activities produce a lot of moisture very quickly. You can reduce this by:

- Covering pans when cooking and not leaving kettles boiling.
- Drying washing outdoors on a line or putting it in the bathroom with the door closed and the window open or extractor fan on.
- If you have a tumble dryer, ventilate it to the outside
- Pour an inch of cold water into the bath before adding hot water

2 Ventilate to remove moisture: For example:

- Keep a small window ajar where safe to do so or putting onto window lock
- Ventilate kitchens and bathrooms when in use by opening the windows wider or using an extractor fan where installed.

- Close kitchen and bathroom doors when they are in use. This will prevent moisture meeting other rooms.
- Avoid putting too many things in wardrobes and cupboards which will stop air circulating.
- Avoid pushing furniture right up against walls so air can not circulate around it.
- Remember not to block trickle or ventilation grilles and air bricks, as they're important to the performance of the building.

3 Insulate, draught proof and heat your home:

- In cold weather keep a low background heat on all day anything above 15 degrees.
- Fit draught proofing to external doors and windows (not in the kitchen or bathroom)

How to stop condensation forming

- You need to take the steps mentioned previously to deal reduce humidity levels but there are some simple measures you can undertake right away to help reduce mould growth.
- Wipe down windows and sills and other surfaces where condensation forms on a regular basis.
- Wring out cloths rather than drying them on the radiator.
- Wash or replace a shower curtain regularly
- How you can help to tackle mould
- Vinegar is a mild acid which can kill 82% of mould species. However it also has the advantages of being natural and safe. Vinegar is non-toxic and doesn't give off dangerous fumes like bleach does. Put white vinegar in a sprayer or bowl, wipe or spray on mould leave for an hour and then wipe down. This may need to be repeated regularly to reduce re appearance
- Use baking soda to kill mould in your home.

Unlike other mould killers which contain harsh chemicals, baking soda is mild (pH of 8.1) and harmless to your family and any pets. Add one quarter of a tablespoon of baking soda to a spray bottle of water. Wipe down the mouldy area with the baking soda and water solution. Scrub away the mould. This may need to be repeated.

- You can combine the vinegar and baking soda as an alternative.
- If the mould is growing on non-porous materials such as tiles, baths, glass and countertops you can if used safely wipe down with bleach and water solution.
- Dry-clean any mildewed clothes and shampoo carpets.
- Disturbing mould by brushing or vacuum cleaning can increase the risk of respiratory problems.

The only solution to avoid severe mould caused by condensation is to reduce the humidity levels that help create the environment for condensation and mould growth.

Leaseholders

How this book applies to leaseholders

If you are a leaseholder, you are responsible for maintaining the internal parts of your own property. However, when these repairs relate to the parts of the structure (e.g. window frames load bearing walls, floor joists, fire compartmentalisation etc.), that responsibility transfers from lessee to landlord. We have therefore devoted a section to the distinction between pages (15 and 16) so you can see where your responsibilities end and the Council's begin.

The booklet also covers repairs to the communal area and we hope the terminology is helpful if you have to report a repair.

If you have a query regarding your lease or your service charges, please give us a call on **020 8753 4500** or send us an email at **service.charges@lbhf.gov.uk**

If you want to make alterations to your home, you must first obtain a landlord's licence from H&F. This is a requirement of your lease. If you don't obtain it you may have problems later trying to sell the property and could also face legal action. A landlord's licence is entirely separate from planning consent and building regulation approval both of which you may also need depending upon your proposals together with a refurbishment and demolition asbestos survey.

Please be aware that fees are chargeable to cover the costs for surveyors, engineers and administrators etc. processing licence applications, the value being dependent upon the complexity of the work. In addition you will also need to pay the Council's legal fees as well as the fees for any legal representative should you choose to appoint one.

If you have any queries please call the Property Compliance team to discuss the matter on **020 8753 4005** or email housing.**propertycompliance@lbhf.gov.uk**.

Leasehold repair responsibilities

If you are a leaseholder, the council is only responsible for the common and structural parts of your building. You are responsible for the internal parts of your home and individual services to it. The table below gives you an indication of how these responsibilities are split, although this is not exhaustive and you should always refer to the terms of your lease or seek advice from us at service.charges@lbhf.gov.uk

Leaseholder's Responsibility	Council's Responsibility
Window glass	The roof*
Partition walls (not loadbearing) and ceiling plaster	External walls
Floor boards and floor coverings	Internal supporting walls
Internal doors	Joists, beams and lintels
Plumbing and electrics servicing leaseholders flat only	Communal doors and frames
Water tanks serving leaseholders flat only	Window frames and sills
Individual heating systems	Guttering, down pipes and soil stacks
All fixtures and fittings	Drains (serving the whole building)

Leaseholders

Leasehold repair responsibilities

Leaseholder's Responsibility	Council's Responsibility
Timber fences in your garden (not party fence walls)	Lifts
	Booster and pit pumps
	Communal alarms
	Communal TV aerials
	Communal heating systems
	Communal external lighting
	Entrance lobbies and stairways (communal)
	Roads and paths
	Gardens (communal)
	Party walls, party structures and party fence walls

* If you had a loft extension completed you may be responsible for roof repairs.



Repairs picture finder and how to use it

Using picture finder

Picture finder is designed to help act as a prompt for you and our customer service centre staff identify the issue you have. On each page there are several pictures numbered, choose the picture that is closest to the problem you have in your home.

Our staff will ask you a range of questions to get further details about how the issue occurred, where it is in your home, how it is impacting on you and if you can send us any pictures of the issue. This will help ensure we give our contractors the correct information so they can diagnose the problem and end the right operative to try and fix the issue.

Repairs picture finder

Baths

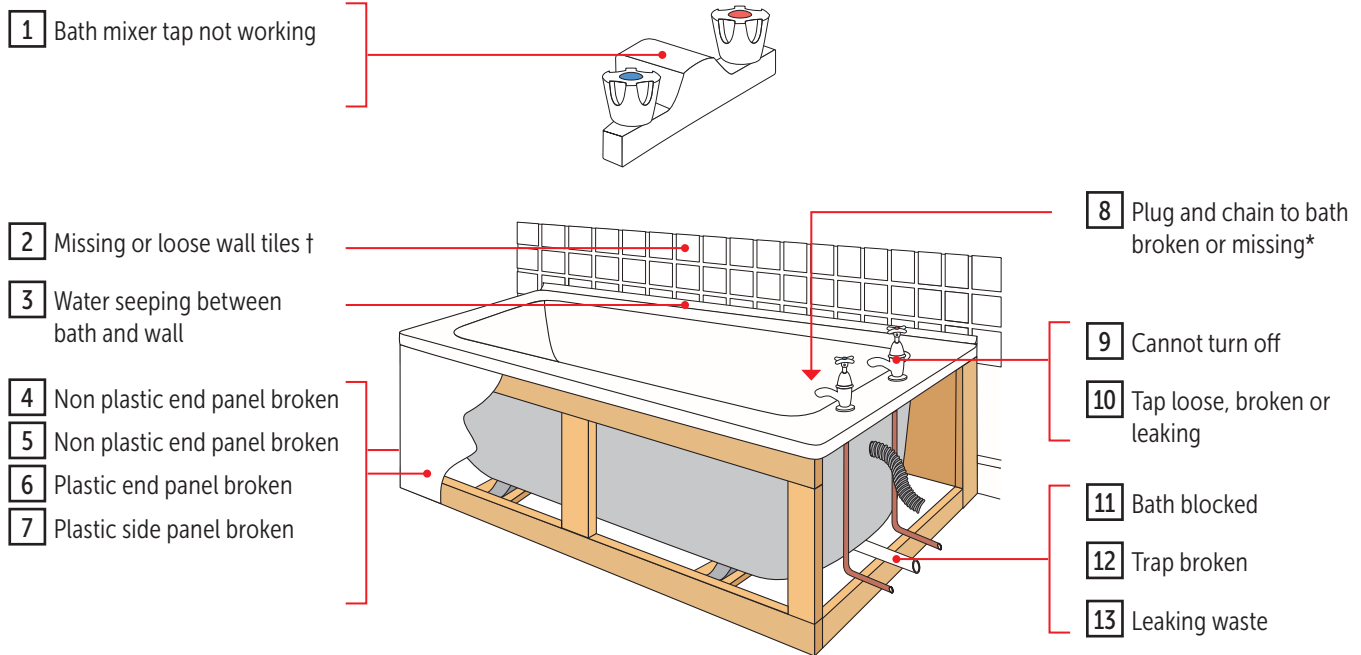

* Repairs are only done for tenants eligible under the discretionary repairs policy.

Repairs picture finder

Showers

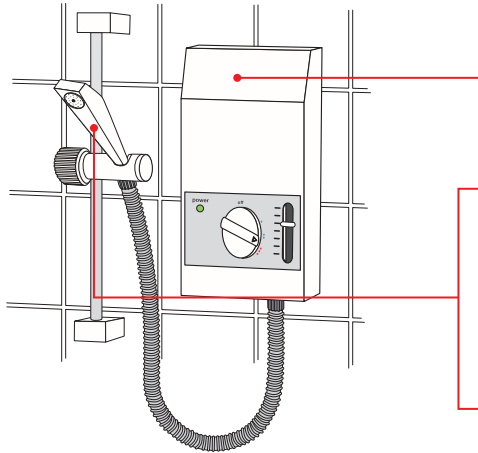

1 Electric shower needs repair

2 Shower spray head needs repair

3 Shower spray head broken

4 Shower hose and spray broken

5 Water too hot or cold

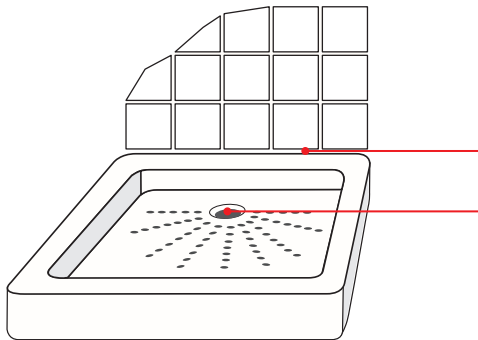

6 Water seeping between shower and wall

7 Shower blocked

Repairs picture finder

Toilets

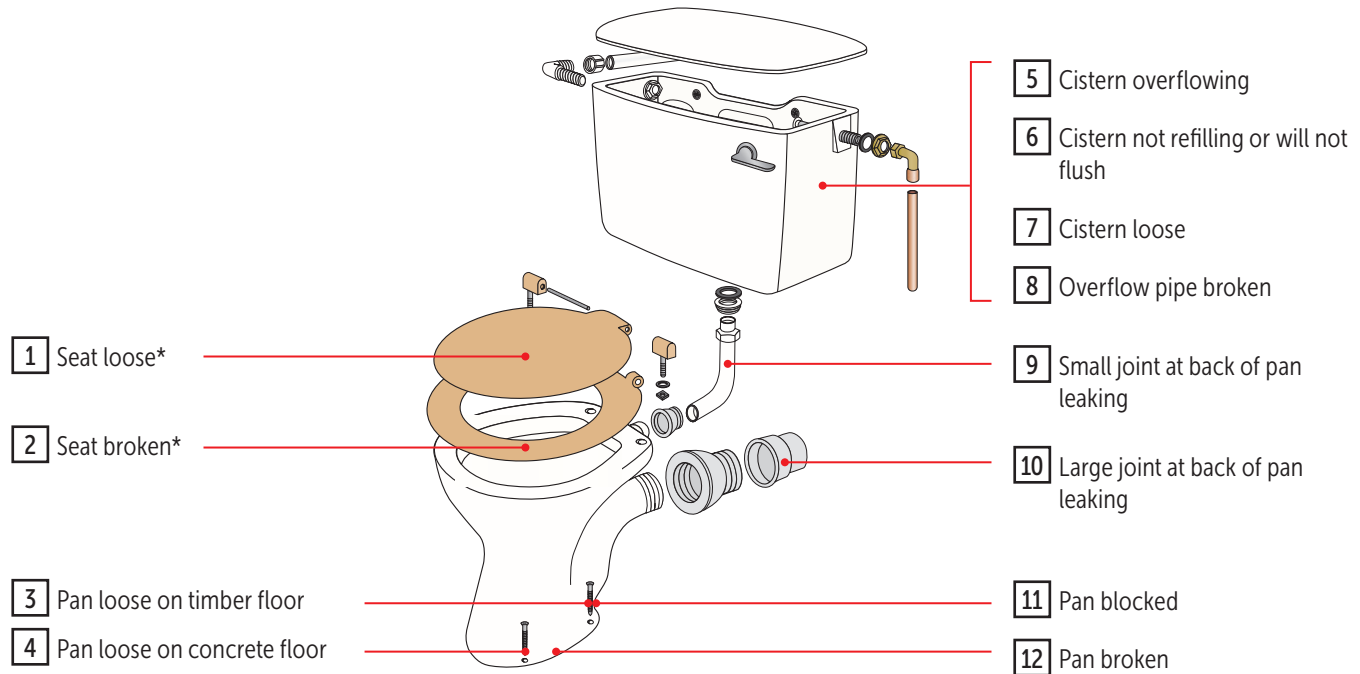

* These repairs are only done for tenants eligible under the discretionary repairs policy.

Repairs picture finder

Sinks and basins

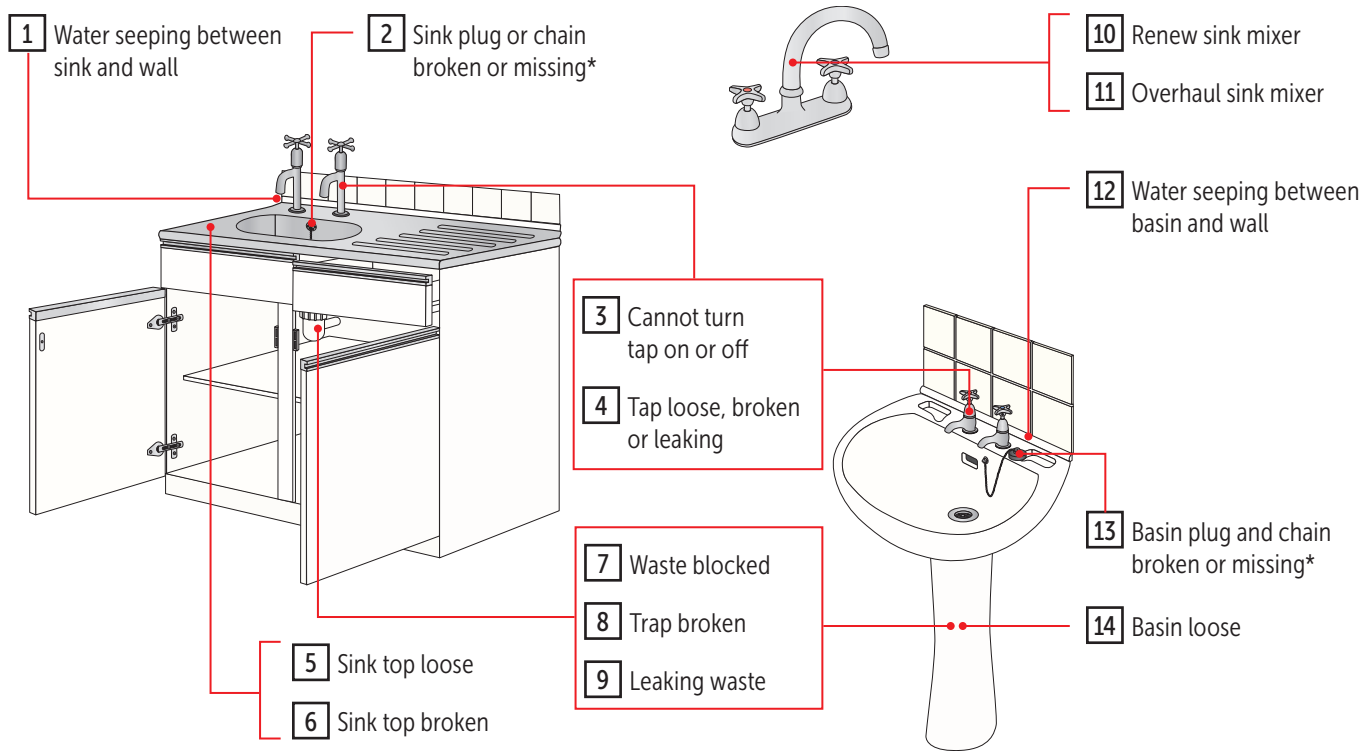

* These repairs are only done for tenants eligible under the discretionary repairs policy.

Repairs picture finder

Kitchen units

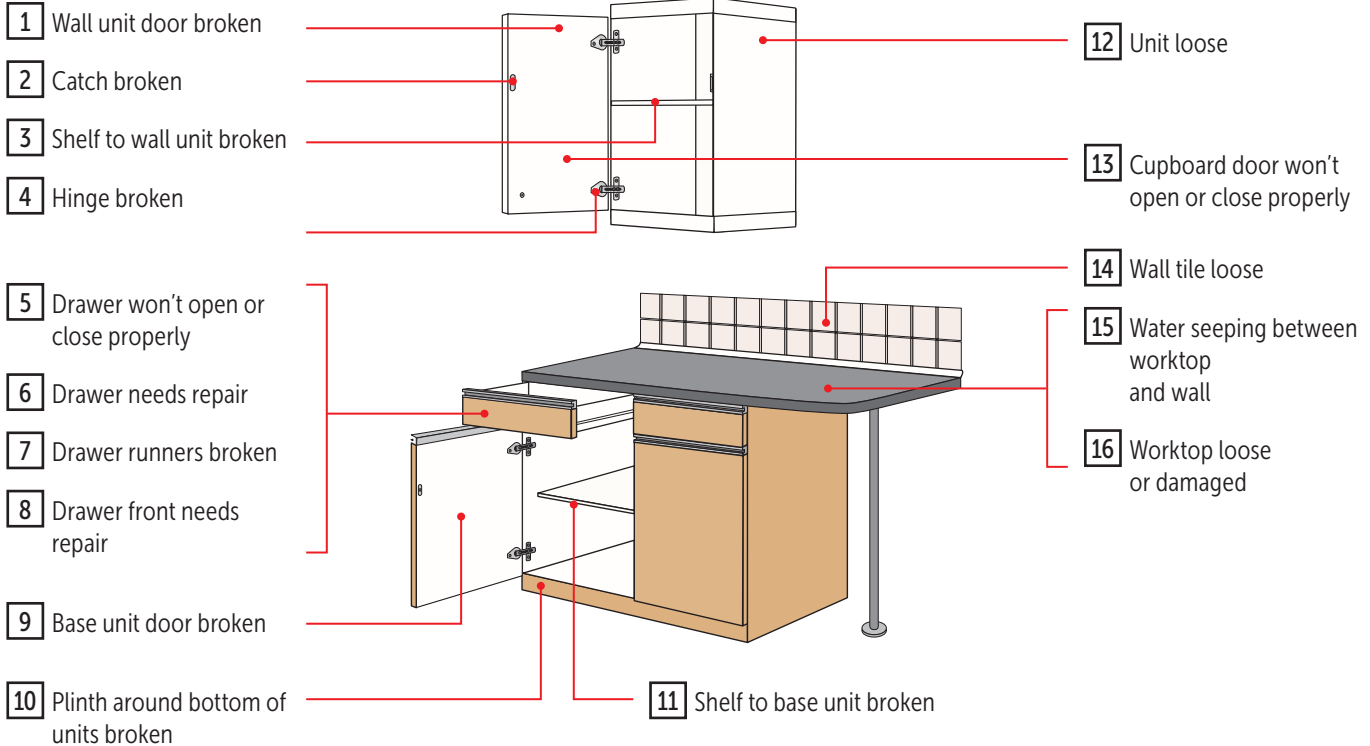

Repairs picture finder

Floors, walls and ceilings

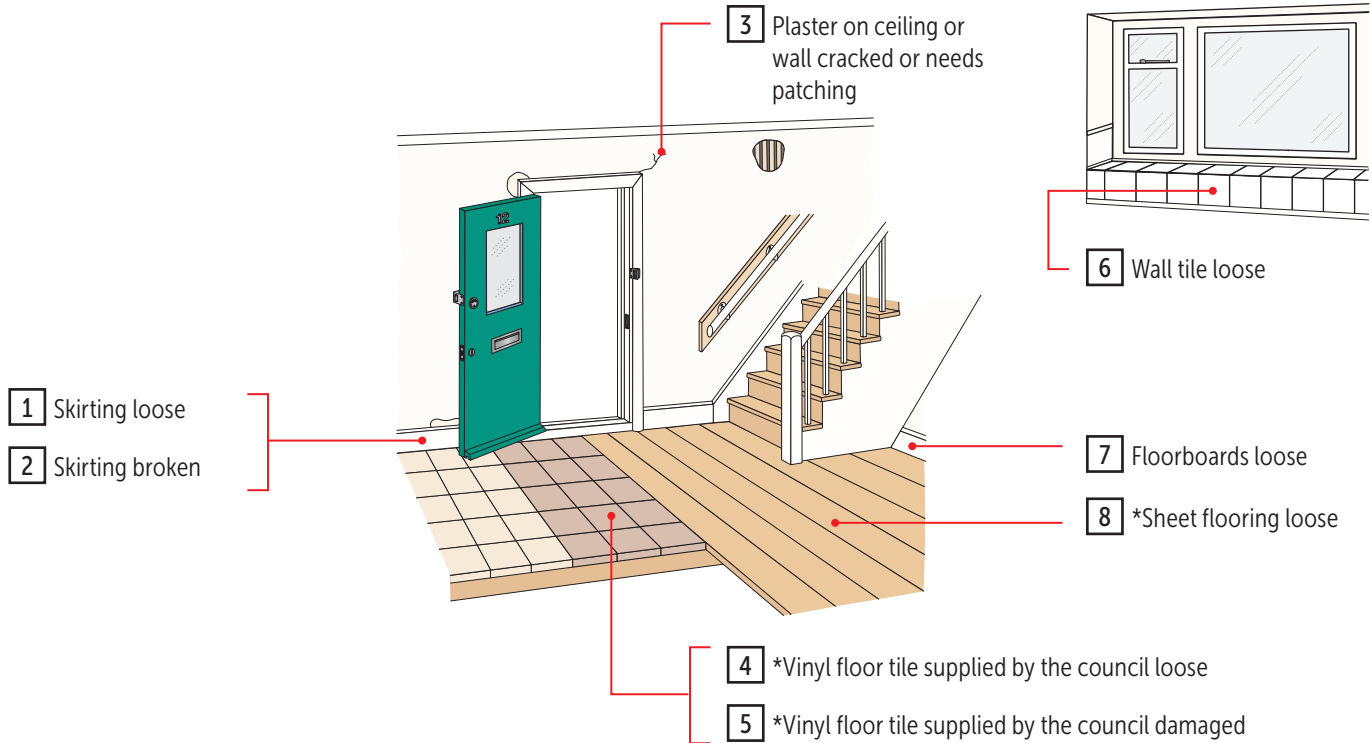

* Repairs are only done for tenants eligible under the discretionary repairs policy.

Repairs picture finder

Stairs

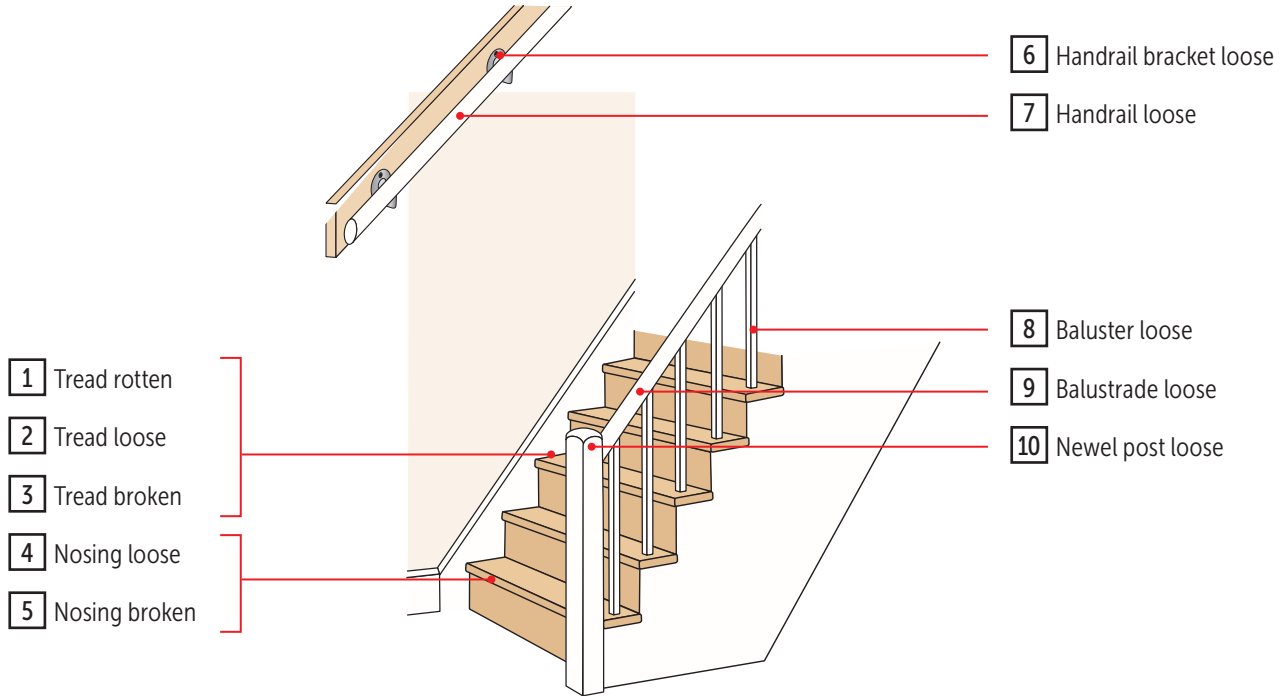

Repairs picture finder

Internal doors and meter cupboards

Meter cupboard*

1 Lock broken

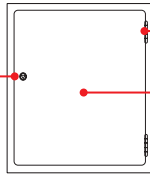

2 Hinge broken

3 Door damaged or missing

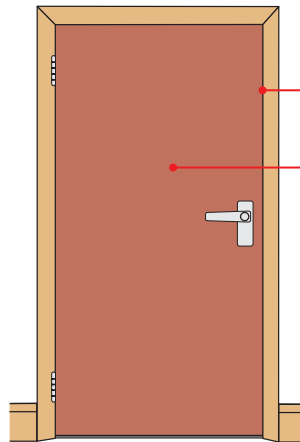

4 *Door sticking

5 *Door needs renewing

* Repairs are only done for tenants eligible under the discretionary repairs policy unless a communal door.

Repairs picture finder

Door closers

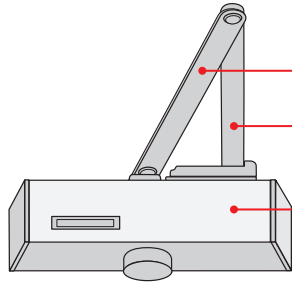

1 Closer on top of door in communal area broken

2 Closer on top of door in dwelling broken

3 Closer needs adjusting

4 Door spring does not open or close properly

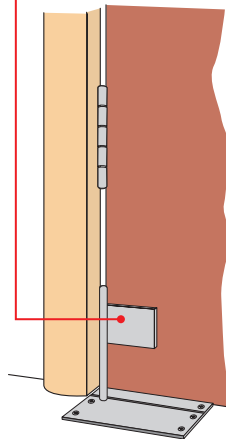

5 Closer on side of door broken

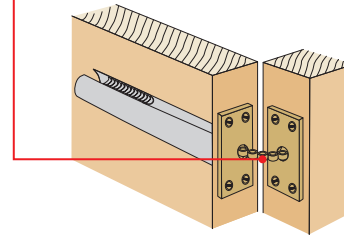

Repairs picture finder

Doors: locks and latches

1 Handles broken

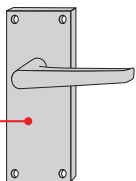

2 Keys to Yale type lock need replacing*†

3 Yale type lock broken

4 Yale type lock needs repair

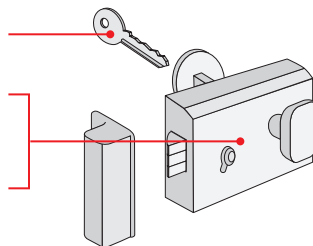

5 Rim lock broken †

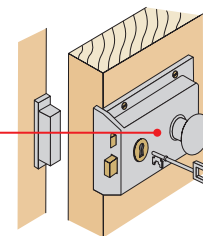

6 Mortice lock with handle broken

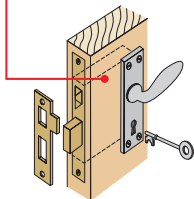

7 Mortice lock without handle broken

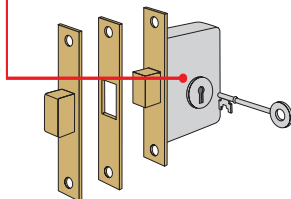

8 Mortice latch needs repair

9 Mortice latch broken

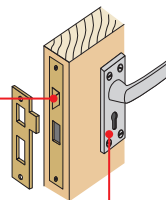

10 Any lock needs repair

11 Insecure outside lock

* Repairs are only done for tenants eligible under the discretionary repairs policy.

† Please see fire safety section for notes on FD30 and FD60 front entrance door.

• Any repairs needed to FD30 or FD60 Gerda doors must be completed by specialist trained operatives.

Repairs picture finder

Doors: fittings

1 Bolt broken*†

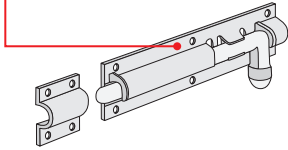

2 Padlock broken or missing*†

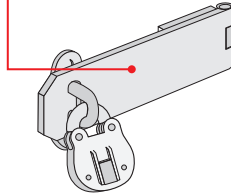

3 Damaged or missing letterbox †*

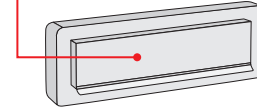

4 Hasp and staple broken or missing*†

5 Door bell not working*†

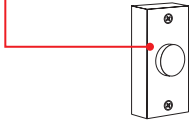

6 Door viewer broken*†

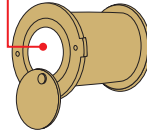

7 Door chain broken or missing*†

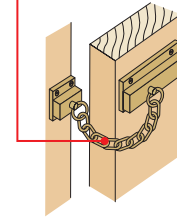

* Repairs are only done for tenants eligible under the discretionary repairs policy, except for privacy locks on bathroom doors.

† Please see fire safety section for notes on FD30 and FD60 front entrance door.

• Any repairs needed to FD30 or FD60 Gerda doors must be completed by specialist trained operatives..

Repairs picture finder

External timber doors

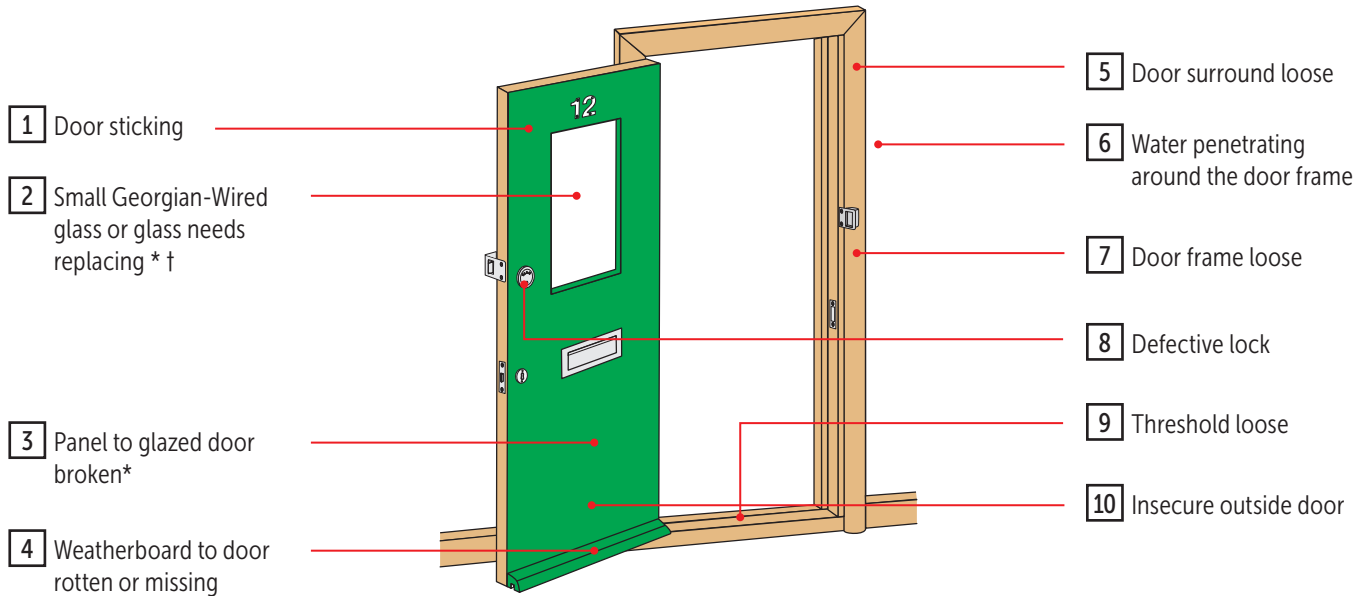

* Repairs are only done for tenants eligible under the discretionary repairs policy.

• Any repairs needed to FD30 or FD60 Gerda doors must be completed by specialist trained operatives.

† Unless it's a fire safety door (residents may be recharged for glazing).

Repairs picture finder

Outside UPVC doors

1 Door needs repair

2 Lock on door needs adjusting

3 Lock cylinder needs renewing

4 Handle broken on door

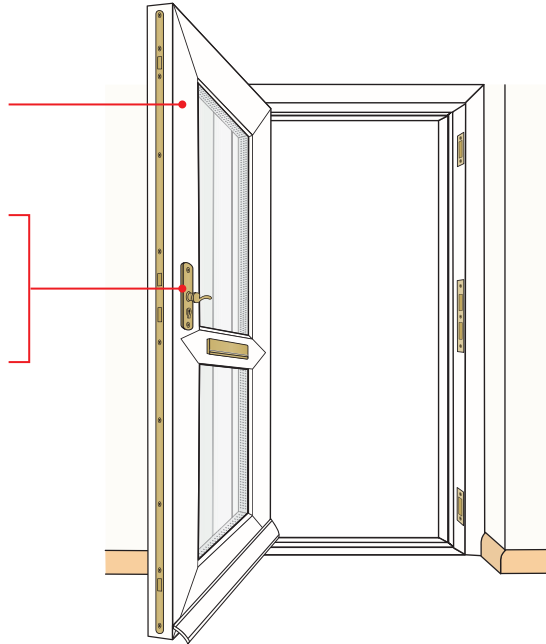

5 Multipoint lock on door needs repair

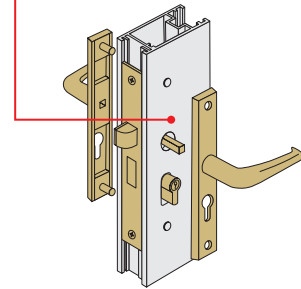

6 Insecure outside door

Repairs picture finder

Glazing: single

Reglaze – small*

- 1 Clear or obscure glass
- 2 Georgian-wired clear glass
- 3 Georgian-wired cast glass

Reglaze – medium*

- 4 Clear or obscure glass
- 5 Georgian-wired clear glass
- 6 Georgian-wired cast glass

- 11 Temporary board before replacing any glazed unit

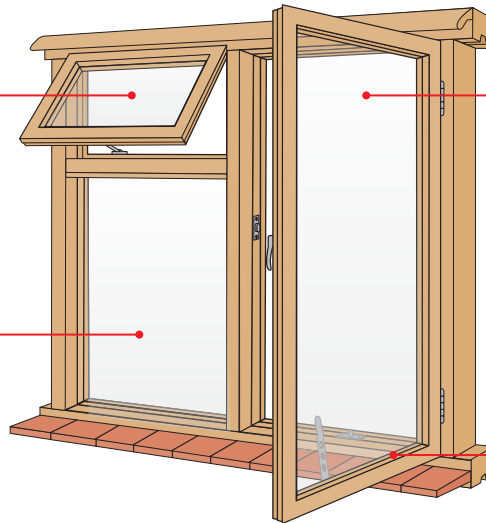

Reglaze – large*

- 7 Clear or obscure glass
- 8 Georgian-wired clear glass
- 9 Georgian-wired cast glass

- 10 Putty broken or missing

* Repairs are only done for tenants eligible under the discretionary repairs policy, a communal window, or where the damage is the result of a crime and you have confirmation from the police

Repairs picture finder

Glazing: double glazing, vents and louvres

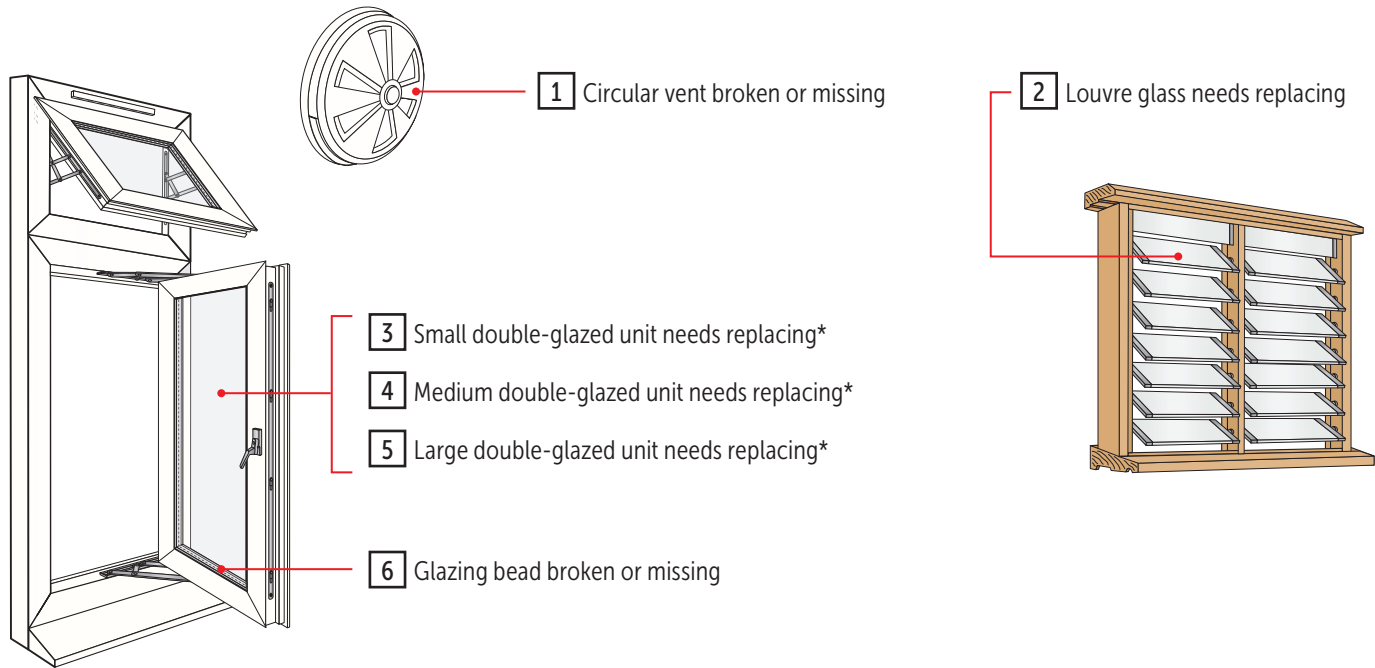

* Replacement subject to an inspection by one of our surveyors

Repairs picture finder

Windows: metal and pivot window repairs

Metal and aluminium

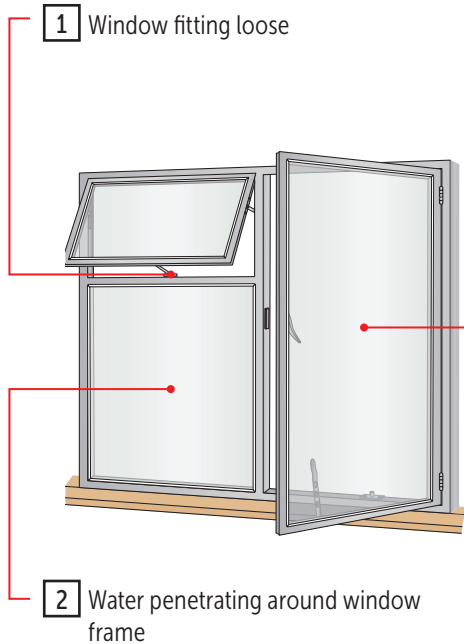

- 3 Metal window won't open or close properly
- 4 Metal window needs repair
- 5 Aluminium sash won't open or close properly
- 6 Aluminium sash needs repair

Pivot

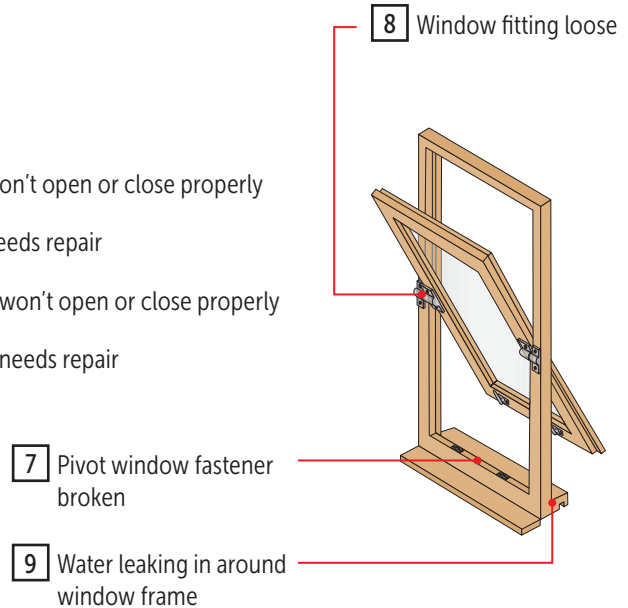

Repairs picture finder

Windows: timber window repairs

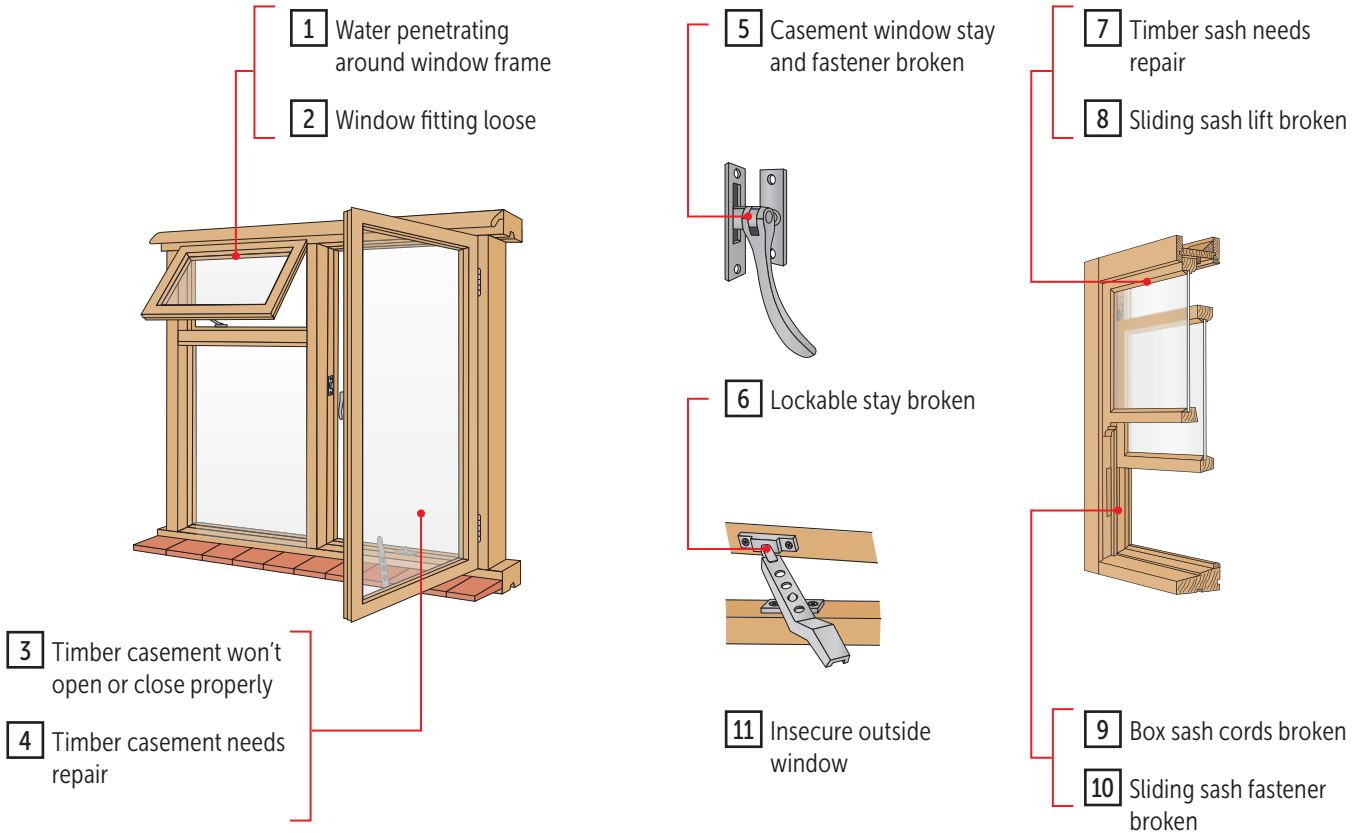

Repairs picture finder

Windows: UPVC window repairs

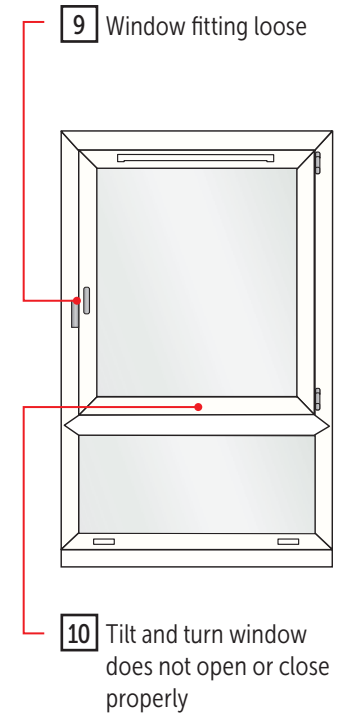
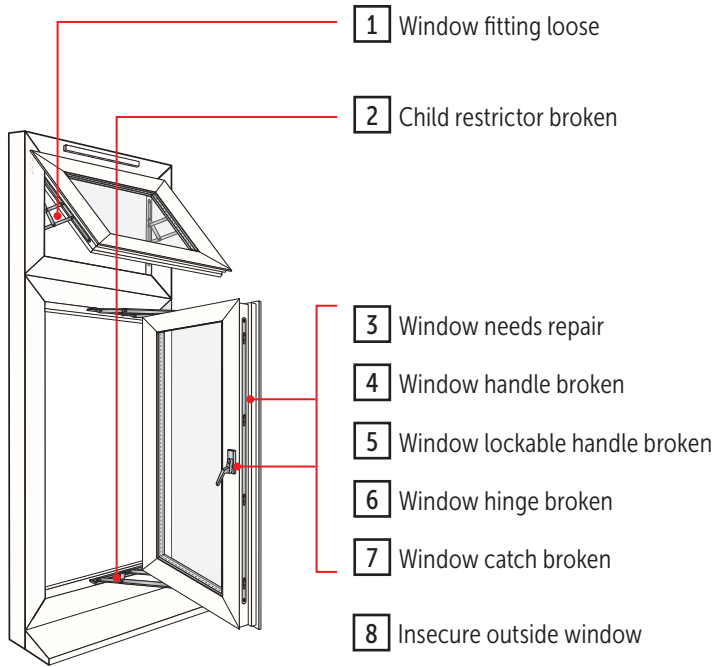

Repairs picture finder

Electrics: lighting

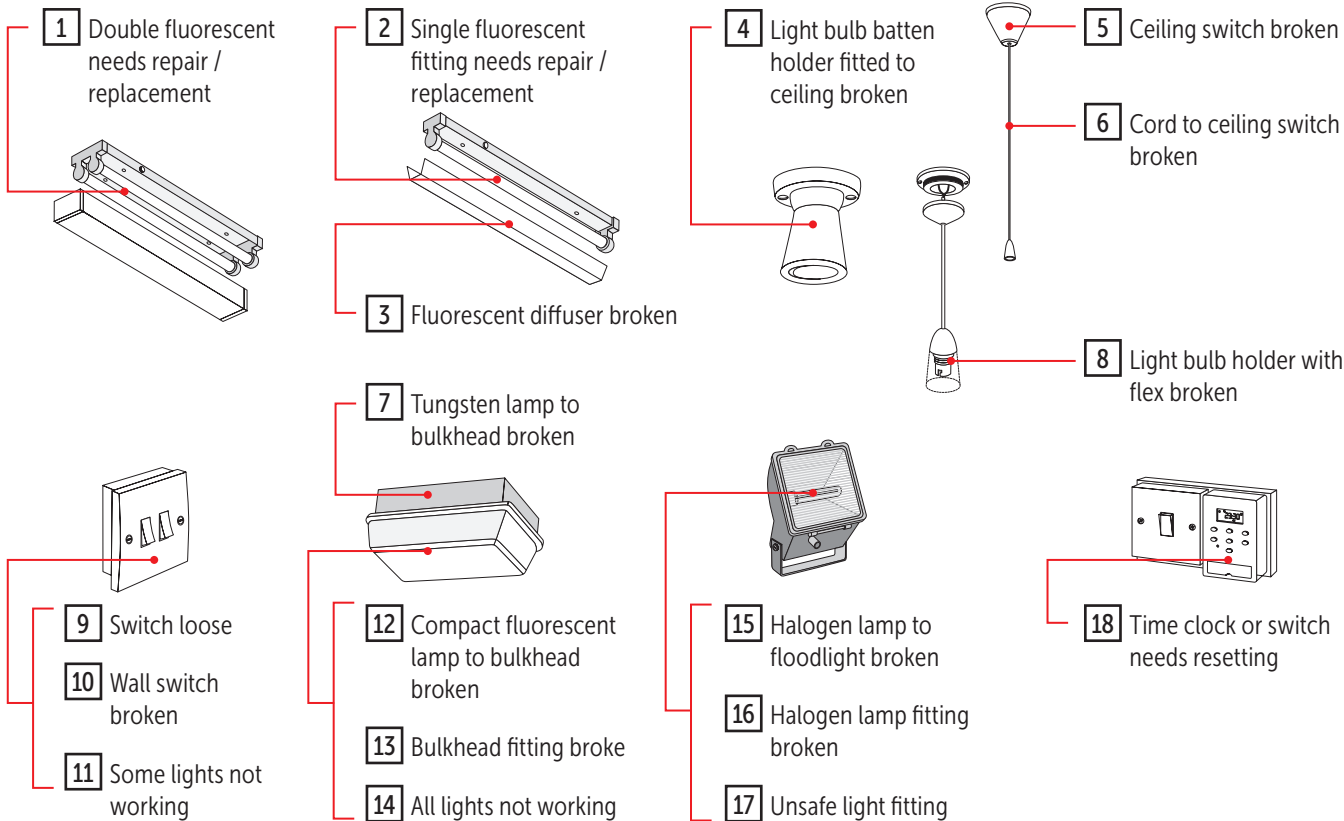

Repairs picture finder

Electrics: power

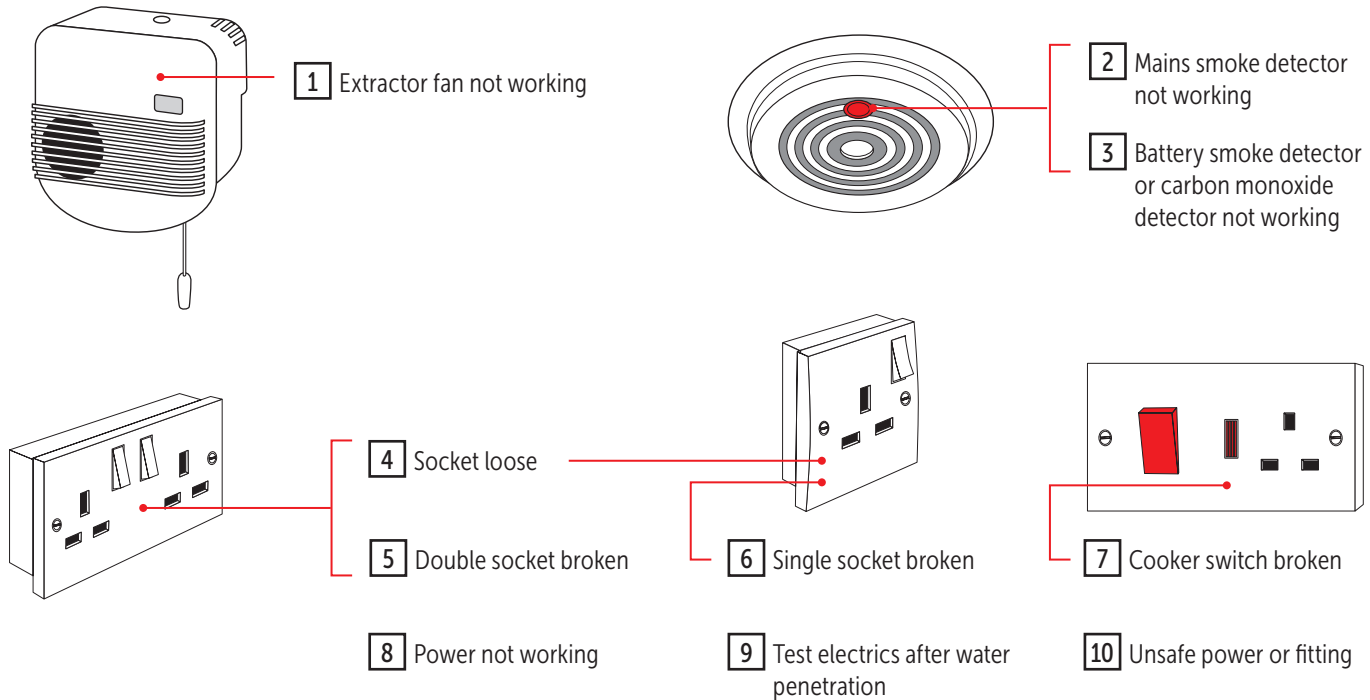

Repairs picture finder

Heating and hot water: individual

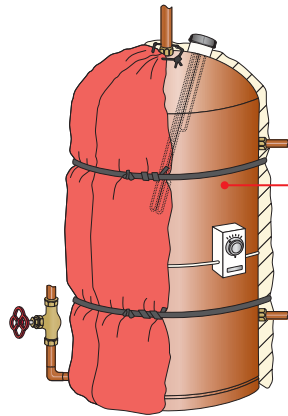

1 Immersion too hot or cold

2 Cylinder leaking

3 Unable to turn radiator off or faulty radiator valve

4 Leaking heating pipe or radiator

5 Radiators not heating up

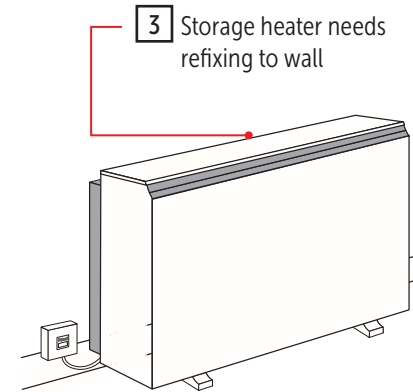
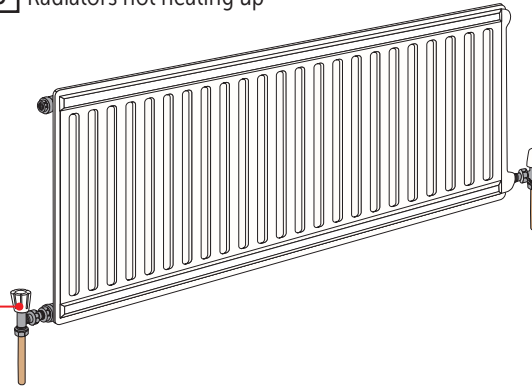

3 Storage heater needs refixing to wall

Repairs picture finder

Heating and hot water: communal

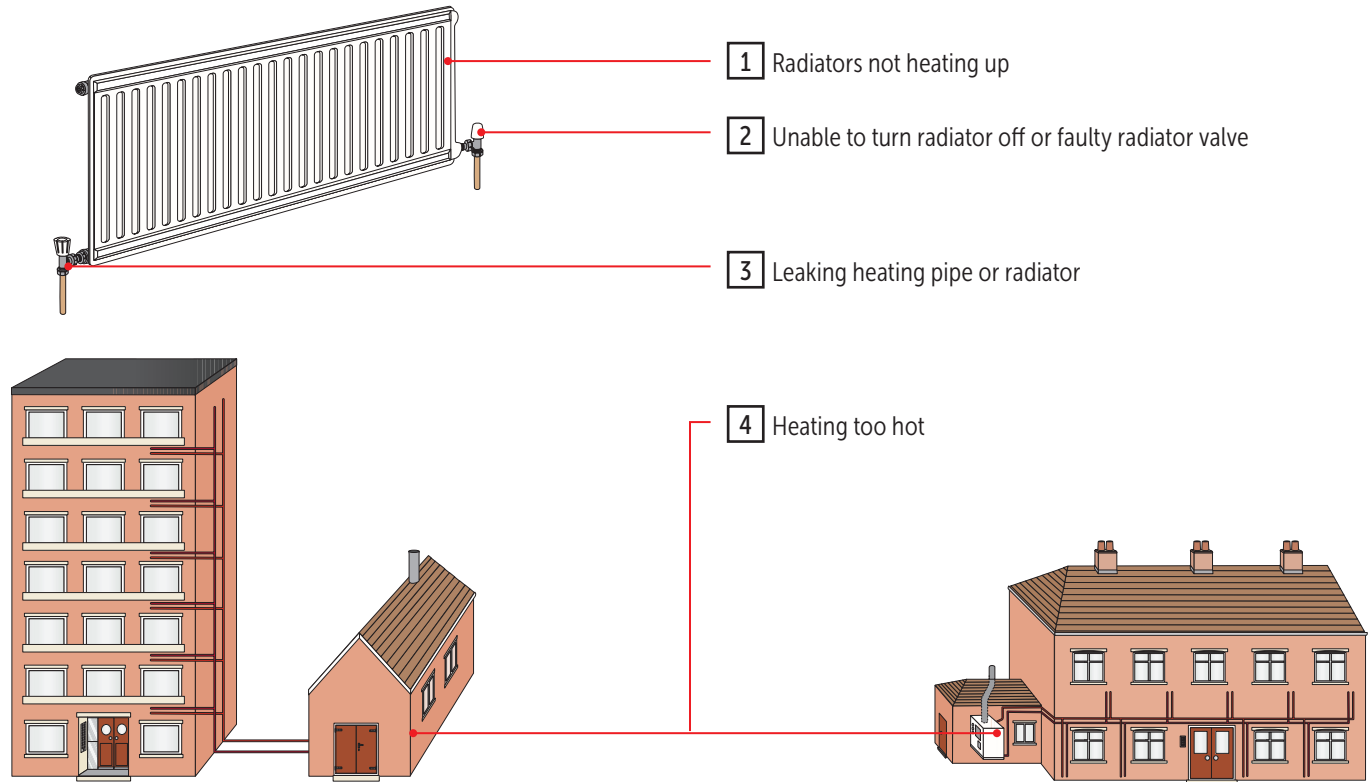

Repairs picture finder

Gas safety

If gas is escaping outside your home

Phone Gas Emergency Service on freephone **0800 111 999** and report a gas leak and follow the instructions of the engineer.

If gas is escaping inside your home

Find the gas meter and turn off the gas mains supply unless it's in the basement.

Phone Gas Emergency Service on freephone **0800 111 999** and report a gas leak and follow the instructions of the engineer.

Main gas on and off lever:

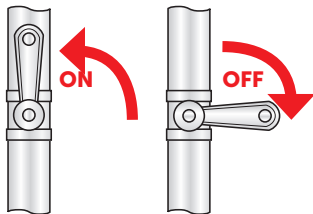

- ✓ Open the windows to ventilate the house.
- ✗ Do not switch on or off any electrical appliance or light.
- ✗ Do not smoke or use a naked flame.

Repairs picture finder

Water services

- 1 Gate valve won't open or shut properly

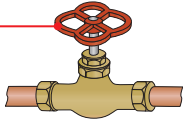

- 2 Stopcock won't open or shut properly

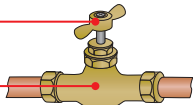

- 3 Stopcock broken

- 4 Water pipe leaking
5 Knocking sound from water pipes
6 Total loss of cold water supply
7 Partial loss of cold water supply

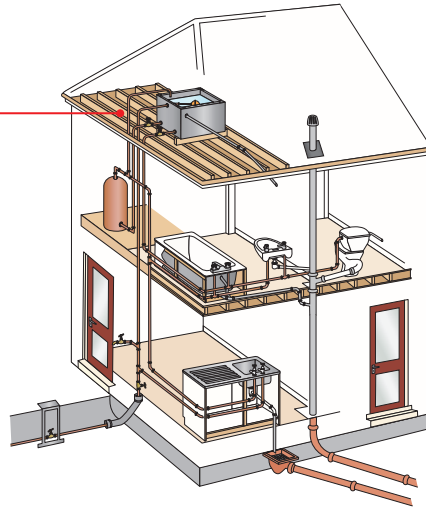

- 8 Cold water tank overflowing

- 9 Cold water tank leaking

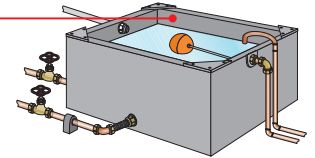

- 10 Service valve won't open or shut properly

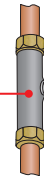

Repairs picture finder

Lifts

In the unlikely event should you become trapped in the lift please follow the instructions below:

- Stay calm
- Push Alarm Button on the control panel and hold for a minimum of 3 seconds and wait to be answered.
- If no answer please dial the lift alarm contact centre on
- 020 8753 2475.
- **Do not call 999 unless it's a health risk.**
- Do not attempt to open the doors as this could be dangerous.

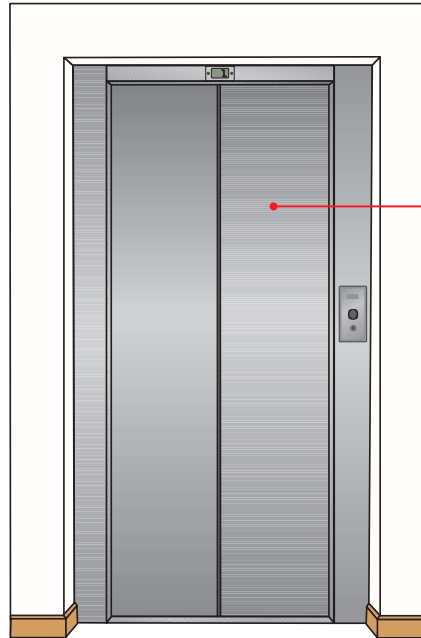

- 1 Lift out of order
- 2 Lift door not closing
- 3 Lift stuck on floor
- 4 Lift not responding to calls
- 5 Fire switch (drop key) broken

Repairs picture finder

Controlled access

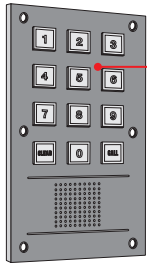
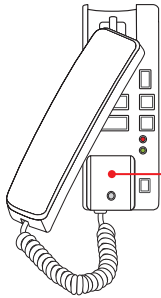

- 1 Visitor cannot hear me / I cannot hear visitor
- 2 No buzzer
- 3 No lock release
- 4 Intercom completely out of order
- 5 Faulty handset
- 6 Reset trades button on main entrance door to standard trade times

- 7 Main entrance door not closing properly
- 8 Main entrance door not locking
- 9 Total breakdown of whole system in block
- 10 Fire switch (drop key) broken

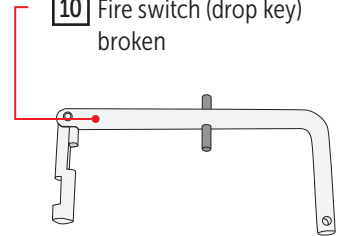

Repairs picture finder

Roofs

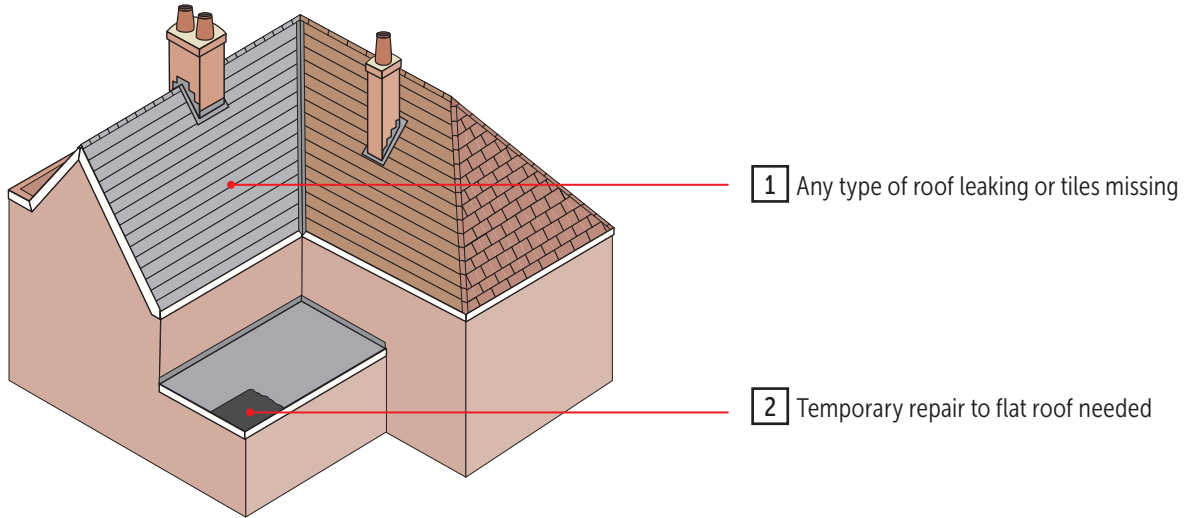

Repairs picture finder

Gutters

- 1 Gutter blocked along elevation
- 2 Plastic gutter leaking
- 3 Plastic gutter bracket broken or missing
- 4 Iron gutter leaking
- 5 Iron gutter bracket broken or missing
- 6 Hopperhead blocked

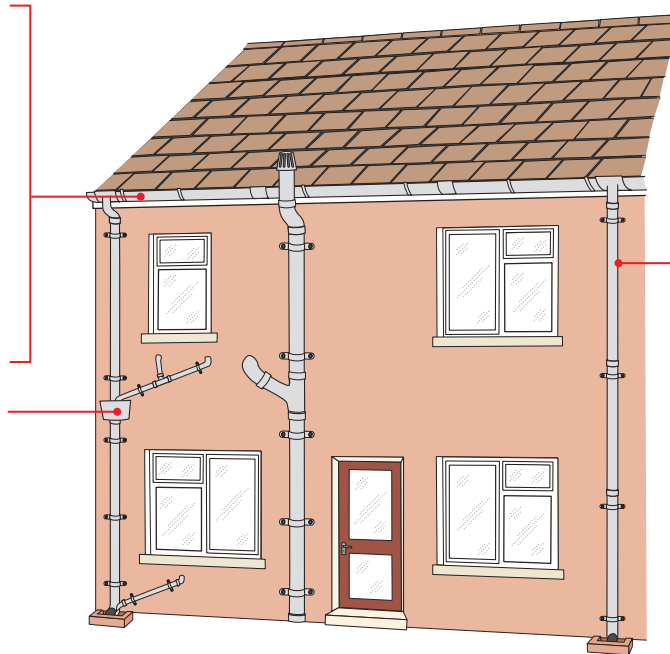

- 7 Downpipe blocked up to two storeys
- 8 Downpipe blocked two to four storeys
- 9 Downpipe blocked over four storeys
- 10 Plastic downpipe leaking
- 11 Plastic downpipe loose
- 12 Iron downpipe leaking
- 13 Iron downpipe loose

Repairs picture finder

Drainage

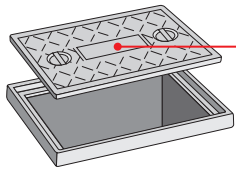

- 1 Manhole cover not opening or closing properly
- 2 Manhole cover and frame loose

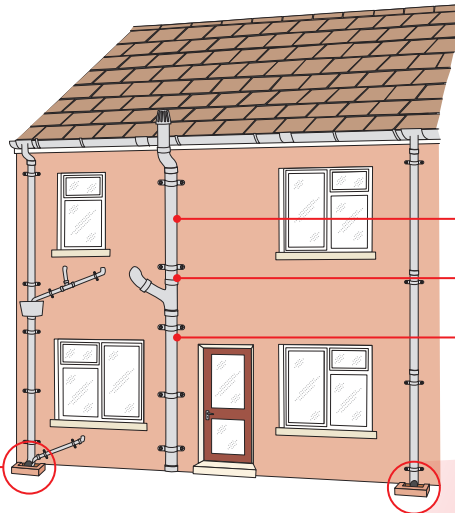

- 3 Drain blocked
- 4 Gully blocked
- 5 Gully grate broken or missing
- 6 Gully surround broken

- 7 Stack blocked up to two storeys
- 8 Stack blocked two to four storeys
- 9 Stack blocked over four storeys

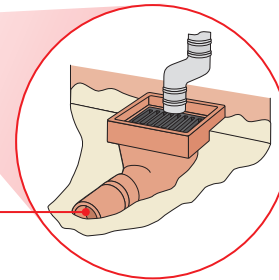

Repairs picture finder

Steps, paving, walls and bollards

1 Step loose or damaged

2 Paving flag or tarmac loose, uneven, broken or damaged

4 Hanging tiles broken, missing or loose

6 Brick coping on wall loose

8 Stone coping on wall loose

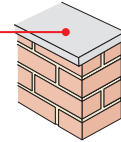
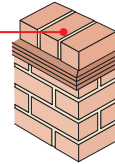
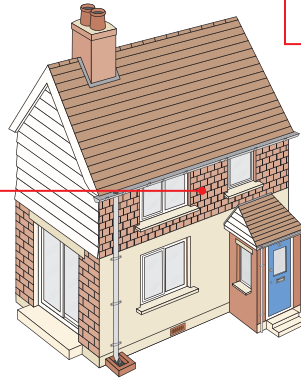
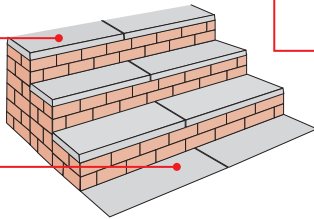

3 Block paving loose

5 Concrete bollard broken

7 Steel bollard broken

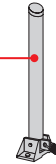
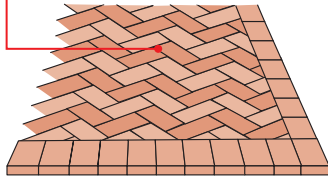

Repairs picture finder

Fences and gates

1 Any type of fence broken or loose*

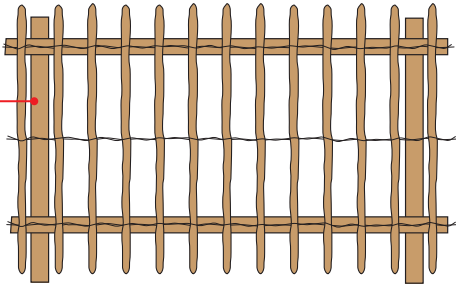

2 Any type of gate broken or loose*

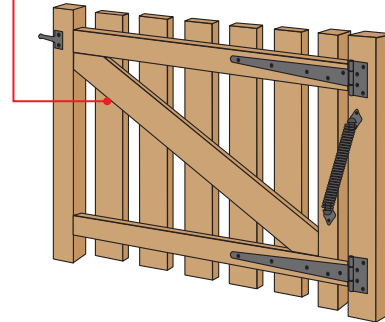

* Unless communal, repairs are only done for tenants eligible under the discretionary repairs policy.

Repairs picture finder

Garage doors

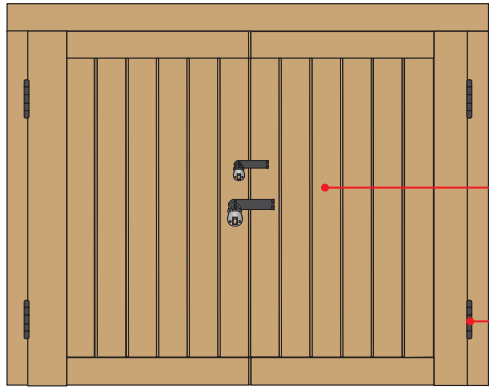

1 Timber garage doors won't open or close properly

2 Hinges broken

9 Cannot gain access to garage*

- 3 Lock to up and over metal garage door broken
- 4 Locking handle to up and over metal garage door broken
- 5 Locking bar to up and over metal garage door broken
- 6 Up and over metal garage door needs repair
- 7 Up and over metal garage door loose
- 8 Up and over metal garage door needs renewing

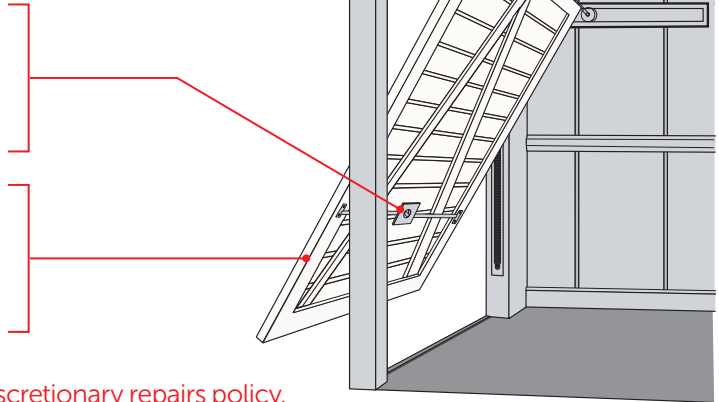

* Repairs are only done for tenants eligible under the discretionary repairs policy.



More about repairs...

More about repairs...

Discretionary support for repairs

There are a selection of repairs that would normally be the tenant's responsibility that we will agree to do to help sustain tenancies for those falling into the following categories: the tenant or a member of their household should be 67 years of age or older and/or in receipt of one or more of the following:

- Disability Living Allowance (DLA) - higher rate of the mobility component or the medium or higher rate of the care component
- Personal Independence Payment (PIP) enhanced rate of the mobility component or enhanced rate of the daily living component
- Attendance allowance (higher or lower rate)
- War Disablement Pension
- Local Authority registered care package.
- Voluntary or statutory agency providing support
- H&F internal referral.

You will be advised of your eligibility for discretionary support for repairs. Where your eligibility is not time limited this will be entered into our system so we know in advance should you request the service.



More about repairs...

Discretionary support for repairs

The type of work we make take responsibility for, to help individuals maintain living in their home could include:

- Helping with clearing of properties as a result of hoarding
- Helping with cleaning of properties where there are health hazard concerns
- Fitting additional security measures due to harassment, hate crime, domestic abuse
- Fitting additional electrical sockets for medical equipment.
- Minor repairs* that we may support residents who are eligible for discretionary support could be but not limited to:
 - Replacing a toilet seat
 - Replacing a light bulb in a pendant light fitting
 - Bleeding a radiator
 - Changing the time on a boiler controls/ timer controls
 - Replacing lost keys
 - Replacing door lock after losing keys

(except fire doors)

*Jobs that may require some limited skill, equipment or tools such as screwdriver or hammer to complete.

If a resident is not eligible for the discretionary support for repairs, any minor repairs are their responsibility to complete.

Sheltered residents' handy-person service

For residents living in sheltered accommodation we offer an enhanced service to help with issues that are not classed as repairs. Our handy person scheme maybe able to help with issues including:

- Hanging curtains
- Assembling small item of furniture
- Putting up shelves
- Hanging pictures.

1. How do I request this service?

All requests for the handy-person service should be made via the Customer Service Centre.

2. What happens next?

We will book an appointment with you and one of our direct labour organisation (DLO) will do the works. They will be booked in when the team is in your area.



Please note that you will be responsible for buying any materials or similar items that require installation or replacement except for bathroom and kitchen lights that have a screw diffuser fitting.

More about repairs...

What we need from you to help us

You must tell us about issues with your home as soon as you notice them.

When you report a repair you can help us by having the following information ready:

- Your name
- Address
- Phone number/email address
- Times when you're available to have the works done
- As much information and detail about the issue as possible including how and when it happened, where it is in your home (you may find the repairs finder section useful for this)
- We may ask you to take photos and send them to us so we can identify what's causing the issue.

If you're not going to be in for your appointment please let our customer service centre know soon as possible.

What else you can do to help:

- Let our customer service centre know if the contractor doesn't turn up as arranged
- Always have your job number when you contact us
- Make sure the area to be worked in is cleared
- Keep children away from where the work is being done
- Keep pets in another room if possible
- Give us feedback (both good and bad) so we can improve the service delivered.

You may want to take photos before and after the repair.

Please note that we may ask to take photographs as a record of work - you have the right to turn down this request.

Operatives can refuse to work at your home if their health and safety, or yours, is at risk.

All operatives working for H&F Maintenance will have ID.

Respect, security and identification



Never let someone into your home without verifying who they are first and why they are there.

If you're not sure who is at your door please call our customer service centre on **0800 023 4499**.

Safety

Our contractors will:

- Guarantee staff, workers and sub-contractors are suitably skilled and competent
- Always follow health and safety procedures and never put anyone at risk
- Guarantee particular care is given when children are present, and never enter a resident's home or continue working, where children (under the age of 16) are unaccompanied.
- Provide additional help and show extra consideration to elderly residents or anyone with special requirements.

More about repairs...

Respect, security and identification

Consideration and standards of behaviour in your home and neighbourhood

Our contractors will:

- Always let you know if they're going to be late for an appointment with a revised estimated time of arrival
 - Always have shoe covers
 - Always carry a photo id card and show it to you when they arrive at your home
 - Be professional, polite and courteous at all times
 - Respect your homes and belongings
 - Respect your knowledge of your home
 - Communicate effectively the works to be completed
 - Not use offensive language or behave in an improper manner
 - Try to minimise noise and disruption
 - Never smoke or vape in your home, or directly outside your doors/open windows
- Never use your electricity, toilet or washing facilities without your permission
 - Never play music when working in or around your home, without your permission
 - Drive and park considerately at all times, leaving contact details visible if using a resident's bay
 - Be properly dressed at all times in clean company uniform.

Clean and tidy

Our contractors will:

- Leave your homes and communal areas secure and clean & tidy
- Protect flooring using clean dust sheets where necessary
- Never leave tools and/or materials overnight in residents' homes without their permission (and at contractor's own risk)
- Remove or recycle all waste materials on the same day and remove from site- not using your bins or the communal bins.

Responsibility

Our contractors will:

- Communicate only with the resident or their officially appointed representative
- Guarantee that all information concerning residents is kept strictly confidential at all times, and is only used in accordance with data protection principles
- Monitor levels of customer satisfaction and aim to resolve any complaints within ten working days
- Listen to residents' feedback and take resident comments on board where possible, to improve the overall service.

More about repairs...

How we prioritise and chargeable repairs

How we prioritise your repairs

Although we aim to attend to repairs as quickly as possible, we cannot carry out every repair straight away, so we have to prioritise different types of repairs.

The customer service advisor will always tell you the date the repair is expected to be completed by and ask you to make an appointment for non-emergency repairs and give you a job number.

Some things that may delay a repair are:

- Bad weather conditions like heavy rain, heavy snow fall, or high winds
- Waiting for utility companies to fix a problem before we can complete the repair, for instance if there is a burst pipe
- Consulting with leaseholders in your block about certain repairs. This is a legal requirement called a Section 20 notice and we cannot do the repair until the consultation notice period has ended
- Where we need to gain access or coordinate

with your neighbours to complete the repair

- Where we need to get a specialist survey completed
- Where we need to turn off the utilities to your whole block to complete the repair.
- Where the works require some specialist material or a specialist solution
- Where we need to get planning or building control permissions.

Our aim is to try and understand what is causing the problem and find a solution.

Chargeable repairs and your responsibility

If we're asked to carry out a repair which is not the landlord's responsibility, in most circumstances we will not carry out the repair. If we do carry out a repair which is not our responsibility, we will charge you the cost of the repair. This is known as a chargeable repair.

Priority and targeted completion times

Priority	Response Time
Emergency (4 Hour)	Within 4 hours
Emergency	Within 24 hours
Routine	Within 20 working days
Planned	Within 60 working days

Emergency repairs

Emergency (within 4 Hours)

We aim to attend your emergency repair within 4 hours and initiate make safe, an example is a burst water tank affecting multiple properties.

Our first priority is to make the property safe to prevent further damage and / or to remove the immediate danger.

Emergency (within 24 hours)

Our first priority is to make the property safe to prevent further damage and / or to remove the immediate danger.

Examples of emergency repairs: total loss of power, no toilet, no heating and hot water, communal door entry not working (It may take longer to carry out a permanent repair and a follow-on appointment may be required).

Our customer service team aims to keep you informed at all stages.

More about repairs...

Priority and targeted completion times

Routine repairs

(Within a maximum of 20 working days)

If the repair cannot be resolved immediately, a temporary solution will be put in place until a permanent repair can be carried out.

Examples of routine repairs are: minor leak, dripping tap, repairs to windows.

If the situation changes whilst you're waiting for the repair to be done please let the customer service centre know.

Planned repairs

(Within a maximum of 60 working days)

We aim to carry out planned repairs within 60 working days.

Examples of planned repairs are: more complex works that may require multiple visits – plastering, walls, replacing individual windows, replacing individual kitchen units.

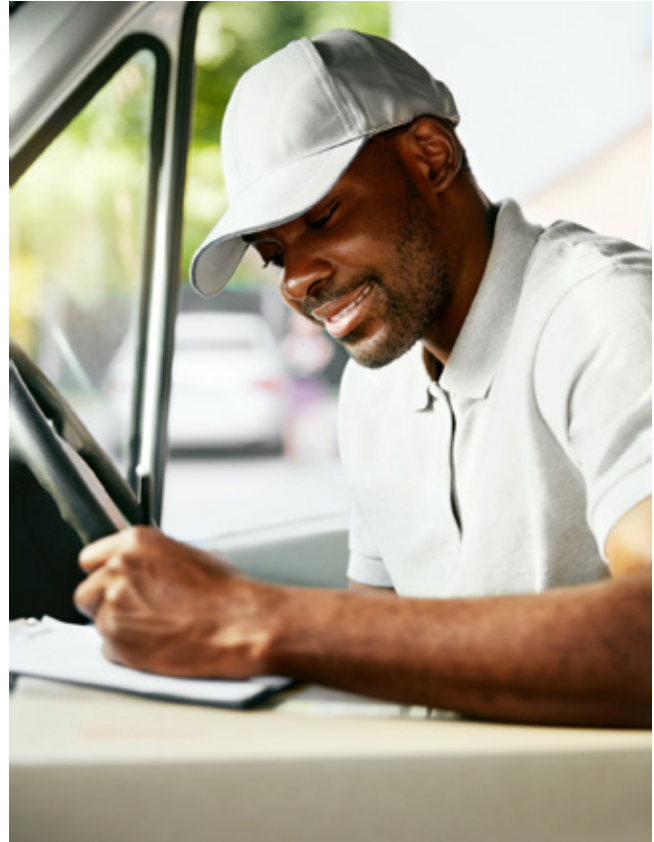

Emergency repairs

Emergency repairs include;

- Structural failure
- Fire damage
- Asbestos fibre release
- No power to all the property
- Gas leak
- Total loss of heating and hot water
- Back surge of sewage impacting on one or more properties
- Blocked toilet where only one toilet at the property*
- Water leak (depending on severity and impact on other adjoining properties)
- Property not secure due to damage to ground floor window or door
- Customer cannot gain access due to lost keys*
- Fire alarm, smoke detector or CO detector failure
- Lifts not working
- Total loss of communal lighting in blocks



- Any other repair that is deemed to be dangerous.

*In some circumstances customers will be charged for repair work. For example, when nappies or other unsuitable items have been flushed down the toilet causing the blockage.

More about repairs...

Repairs on defects / planned works

When planned works are undertaken on your home, building or estate there can be some initial problems with new fittings, furnishings and systems. We understand the frustration this may cause and that you want these matters dealt with, but these are not treated in the same way as routine repairs.

If an item, such as a door handle or cupboard door is not working within the first 12 months, this is known as the defect period. We will collate all known problems and within the defect period carry out a programme of defect works.

These works cannot be reported as a day to day repair.

We have a dedicated team that can help you get your defect repair scheduled. We cannot categorise these in terms of our routine repairs times and may defer these works for a short period.

Generally the team that carries out the defect repair is the programme team that does the actual works. They are best placed to return to a

property to carry out to do the works.

We list all the defect repairs required and carry out a "sweeping up" programme by block / estate or area to cover all defect repairs.

We will give you all the information you need when we come on site to do planned works.

Common questions

How will I know you have ordered my repair?

You'll be given a job number and appointment or targeted completion date at the time you report the repair. If you do not receive this please ask for it - this job number is to be used for any future queries relating to the job in question.

Will you re-confirm the appointment on the day?

If you provide your mobile number a confirmation text will be sent to you.

What if I am out when you call?

If you are out when we call to carry out an inspection or repair, a card will be left at your home and you should call us back to make another appointment. We will try to contact you a further three times by phone. If we are still unable to contact you after 10 days, we will close the job.

You will need to contact us to raise a new job

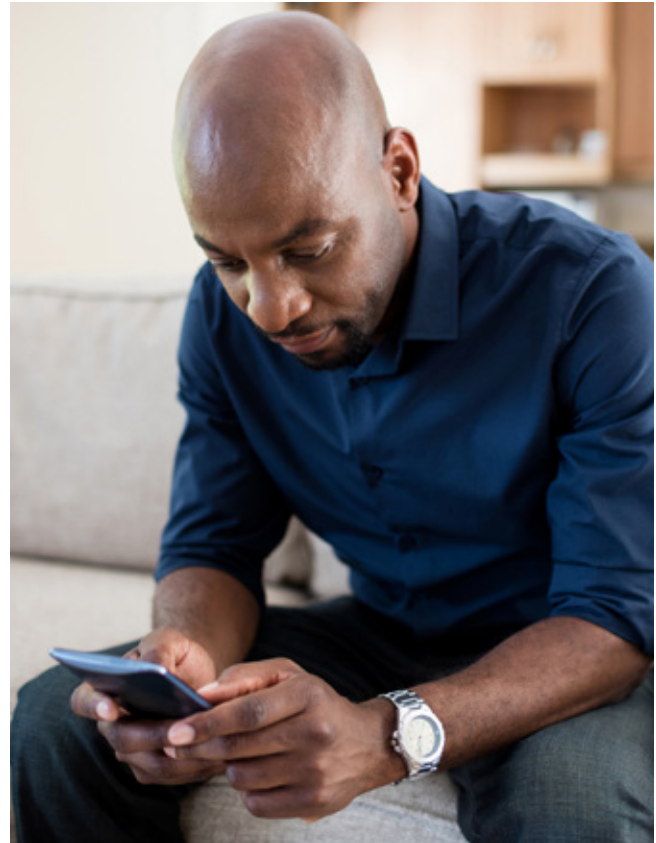

More about repairs...

Common questions

Do I need insurance?

We are responsible for insuring the properties which we own. Any works that H&F is obliged to carry out as the landlord may be covered by the buildings insurance.

Tenants are responsible for insuring their own personal contents (see council tenant's insurance scheme).

www.lbhf.gov.uk/housing/council-tenants/your-tenancy/week-one-your-new-home

We will rectify any damage we cause by attempting repairs and improvements.

We strongly advise you to insure your contents such as furniture, belongings and decoration.



Do I need permission to carry out work?

You are unlikely to need our permission for such matters as putting up shelves or decorating your home.

Some things are not allowed:

- If you are an introductory tenant (a tenant in the first year of your tenancy), we can't agree any alterations
- You can't alter communal areas of the building
- You can't use any communal areas of the building to carry out your works (e.g. your contractor can't use the communal areas to saw timber)
- DIY works are not permitted - you must employ competent professionals. Please refer to the website **www.competentperson.co.uk** for more information and advice.

However, if you're a secure tenant and want to improve your home or to make alterations to your home, you must get the council's permission before starting any works.

This is part of your tenancy agreement. If you don't keep to it, you could face serious consequences including legal action. If you make alterations without consent, you could also have problems if you decide to exchange it or buy it under the right to buy scheme.

'Landlord's consent' is not the same as planning consent or building regulations consent, which you may also need along with a refurbishment and demolition (R&D) asbestos survey if you would like to carry out major alterations to your home.

More information: **www.lbhf.gov.uk/alterationscouncilproperties**



H&F approach to repairs and maintenance

Planned programmes

H&F Maintenance will aim to deliver our landlord repair and maintenance obligations through a range of approaches including;

Planned programmes of replacements	For key parts of a property we have identified how long on average we would expect them to last before we need to replace them. The expected life-cycle of an item is a guide only and we would consider this with what information we hold on the property and the profile of residents.
Planned programmes of improvements	Making improvements to your home that were not there before an example could be, fitting enhanced fire protection.
Cyclical maintenance or servicing programmes	Service or repair works at an agreed interval such as annual servicing your heating system, five yearly testing of electrics.
Reactive repairs	Dealing with day to day issues as they occur i.e., when things fail or go wrong. When we carry out a reactive repair we are trying to get an item working or fit for purpose again.

H&F approach to repairs and maintenance

Misuse, damage or neglect

If the repair is as a result of misuse, damage or neglect, we may advise you that you would need to get the work done by someone else. The Council may agree to do the work for you but the costs of doing the work would be recharged to you. Examples could include a toilet blocked by a nappy; sink blocked by fat, fist holes in doors or walls, damaged kitchen worktops by not using a chopping board, mould growth from condensation caused by lifestyle choices only- e.g. not using extractor fans, not opening windows.

If the damage is caused as the result of a crime we will take responsibility for this work as long as you are able to provide a crime reference number. This could include window smashed by a stranger, or garden gate pulled off hinges.

We may take responsibility for these repairs if they are caused by:

- A member of the existing household as a consequence/result of behavioural symptoms from a medical issue.
- Someone known to you as a result of

domestic violence.

You may be required to provide supporting details. Supporting details could include evidence from a doctor, hospital letter, support worker (statutory or voluntary) or from a representative of H&F.

Accidental damage

If the repair is result of accidental damage then the Council may consider taking responsibility for the work under the discretionary repairs policy. If we do not take responsibility for the work, we still may do the work on your behalf but you will be recharged the cost of us doing it or alternatively you can arrange for the works to be done yourself (subject to Council inspection).

An example of accidental damage could be not turning a tap off properly and causing water damage.



Your health and safety

Your health and safety

What we're doing to keep you safe: Gas safety

It is a legal requirement under regulation 36 of the gas regulations of 1998 for us to gain access into your home. We will make contact with you 60 days in advance of the expiry date of the last service. The first letter will tell you when we will call, if this is not a suitable day and time for you please call the number provided and we will arrange an appointment to suit. If you're not in when we call, we will leave a card asking you to contact us. We will always try to fit the appointment around you. After three missed appointments, under the gas regulations of 1998 and to ensure your safety we would look to seek forced entry.

This will always be a last resort. The safety check will cover your central heating boiler, smoke alarm and CO alarm along with a visual check of any other gas appliance. A landlords gas safety record will be produced and this will be sent out to you within 28 days. All our Engineers are members of the Gas safe register will have their ID badge with them and will ask you at the end of the checks to sign their hand-held computer.

We also quality check a sample of the gas safety checks and you may receive a letter advising you of this visit.

Please contact our customer service centre on **0800 023 4499** if you want more information.



Your health and safety

What we're doing to keep you safe: Carbon Monoxide

Causes and symptoms of Carbon Monoxide poisoning

Common causes of Carbon Monoxide poisoning:

- Faulty gas appliances or blocked flues and chimneys
- Heavy smoking without ventilation in rooms.

The signs and symptoms are not always obvious. Some people may have a pre-existing condition with similar symptoms. At risk groups include babies and young children, pregnant women and people with heart or breathing problems.

Low levels of Carbon Monoxide

Symptoms can be similar to food poisoning and flu but without the high temperature. Symptoms include:

- Headache
- Nausea
- Dizziness
- Tiredness and confusion

- Stomach pain
- Shortness of breath.

High levels of Carbon Monoxide

These are likely to be more severe symptoms such as:

- Impaired mental state
- Loss of physical co-ordination
- Tiredness and confusion
- Chest pain and/or muscle spasms
- Loss of consciousness

You should test CO alarm fitted in your home each week, if it safe to do so.

Press and hold the test button on the CO alarm. You should hear a loud ear piercing noise. If your CO alarm isn't working call our customer service centre on **0800 023 4499**.

Consult your doctor immediately if you are experiencing any of the above. Call our customer service centre if you suspect a gas appliance in your home may be the cause.

What we're doing to keep you safe: Fire safety

The Council is responsible for carrying out fire risk assessments in communal areas to ensure our residents stay safe in the event of a fire.

Once the assessment has been completed, it will be uploaded to our web site (blocks 6 storey or above only)

For lower rise blocks, residents can request a copy of the relevant fire risk assessment to be sent to you.

For copies of your fire risk assessments and more information on our fire safety plus programme please see: www.lbhf.gov.uk/housing/hf-fire-safety-plus

You can help keep you and your neighbours stay safe:

- By not storing items in communal corridors and staircases.
- By not using BBQs on your balcony (or storing excessive items in this area)
- By not covering your smoke alarms
- By not throwing cigarettes over the balconies
- By not making any alterations to your home in particular the main entrance door to your home especially if it is a new Gerda fire door, either a FD60 or Fd30. This includes not changing or adding locks, spy holes, not painting or fixing anything to it. Any alteration no matter how small can impact on its performance as a fire door.

You must not install security grilles to front doors. These can trap residents in their home in the event of a fire, it will also delay the emergency services in gaining access.

Your health and safety

What we're doing to keep you safe: Fire safety



You should test smoke alarms fitted to your home each week, if safe to do so.

Press and hold the test button on the smoke detector. It can take a few seconds to begin, but you should hear a loud, ear-piercing noise while the button is pressed.

If your smoke alarm isn't working please contact our customer service centre on **0800 023 4499**.

It's important that you have a plan so that you and your family would be able to self evacuate from your home if a fire was directly affecting it.

If you would like to discuss this or arrange for one of Safety First Officers to visit please email **Safetyfirst@lbhf.gov.uk**.

For further advice on fire safety in your home visit: **www.london-fire.gov.uk/safety/the-home** for the latest advice and guidance from the London Fire Brigade.

What we're doing to keep you safe: Electricity



The council has a legal obligation to carry out an electrical inspection to your homes and communal areas every 5 years. The operatives will require access to all rooms in your home to carry out tests and to check all electrical sockets, switches etc.

Your health and safety

What we're doing to keep you safe: Lifts and estate inspections

A working lift can be a lifeline to residents so for all lifts we carry out monthly inspections and testing.

During a service visit, an engineer will check the safety features on a lift, in addition to cleaning, lubricating and adjusting all components for optimum performance. An engineer will record any work carried out and also make recommendations for any repairs or works of improvement that are not covered in the service visit.

We have a rolling programme for lift works and improvements that ensures the safe operations and usage of lifts. We also routinely check electrical wiring throughout communal areas

When major works are required to a lift we will consider all residents' individual needs and may offer to decant* residents whilst the works are taking place.

* Decant means temporary relocation.

We want you to have a feeling of pride about your area, and having a tidy and well maintained neighbourhood is the first step towards this.

Estate Inspections help us to look for things that will improve the area for residents, such as fences, graffiti, overgrown gardens illegal parking and checks on pathways and road surfaces,

Each area has four inspections per year and they are carried out by residents, housing staff and other service providers.

We encourage residents to go on estate inspections to point out areas of concern and provide their views on ideas for environmental improvements.

By getting involved with inspections in your area you can identify issues that matter to you and other local residents.

If you're interested in being part of your estate inspections please contact your housing officer or for more information please see: www.lbhf.gov.uk/housing/resident-involvement/estate-inspections

What we're doing to keep you safe: Water assessment

A clean communal water supply is vital to your health and wellbeing.

Our team carries out risk assessments and tests all water and storage tanks in a property on a regular basis throughout the year. This helps prevent Legionella and other water-borne diseases from being a threat to you and others in your home.

We have a duty to ensure that the risk of exposure to tenants and visitors is properly assessed and controlled.

Legionella bacteria can breed in other places where water is stored such as water systems and cooling towers.

The risk in your home is low because your water is usually stored in temperatures above 60°C and is used daily.



Your health and safety

What we're doing to keep you safe: Asbestos

If your home was built before the year 2000, there is a possibility that it contains asbestos. Undisturbed, undamaged or sealed asbestos is safe. When asbestos is damaged or disturbed the dust and fibres released can be breathed in and can lead to serious lung diseases including cancer. This is why it is important not to damage or disturb materials which might contain asbestos, this includes drilling, cutting, sawing or sanding.

We have responsibilities under the law to manage asbestos risks in non-domestic premises (which includes common areas of blocks of flats) and to record where asbestos has been found – this is known as the asbestos register. When our contractors undertake building work within your home which may disturb materials, your home becomes a place of work and we have to provide the person doing the work with information on whether there is any asbestos present before they can start.

We undertake asbestos surveys during improvement works and when we upgrade

empty homes. Our aim is to gather as much information as possible about asbestos in our properties so we can inform contractors ahead of any work being carried out. If work is due to take place in your home and we don't already have asbestos information held on our register, we may arrange for an accredited asbestos surveying company to carry out a survey, this may include taking samples of materials to analyse. If the survey finds asbestos, we will assess the risk and either remove it, seal (encapsulate) it, or confirm that it is safe to leave as it is. Remember, asbestos in good condition is safe and so we will not normally remove asbestos present in your home unless it is likely to be disturbed.

If you are a Council tenant - under your tenancy agreement you are required to ask us before carrying out any DIY work in your home. This will allow us to check our asbestos records and let you know if it is safe for you to carry on. If you are a leaseholder - it is your responsibility to arrange for an asbestos survey to be carried out if you want to do any work in your home.





**Maintaining the structure
and environment**

Maintaining the structure and environment

Improvements

As well as maintaining the buildings where you live the council is committed to improving your environment. Some examples of improvement projects are:

- Landscape improvements (communal gardens, seating areas, fencing, planting, art features)
- Safety and security (railings, improving paths and secure bike storage)
- Green roofs
- Play areas and ball courts.

We review bids and applications from residents for funding improvements through a resident-led group - The Investment Group - which considers all aspects of bids and the impact on residents.

We do this to ensure the wider community benefits are achieved and that funding delivers improvement for the local community.

For more information or if you have an idea for an improvement please see: www.lbhf.gov.uk/housing/resident-involvement/get-involved-and-make-bid

System maintenance

Door entry systems require maintenance and in some schemes we provide a care system with an alarm – these systems require an annual systems service.

Our door entry systems are carefully checked and refurbished, where recommended, to ensure continuous access and control for you over entry to your block.

Communal aerials are another service we visually inspect and repair when required. These aerials provide access to a wide range of digital TV and radio channels.

Information

Useful contacts

Service	Email	Phone
Abandoned cars (on H&F housing land)	estateparkingproject@lbhf.gov.uk	020 8753 5646
Anti-social behaviour	asbu@lbhf.gov.uk	020 8753 2693
Caretaking/ cleaning/grounds maintenance	ESRequest@lbhf.gov.uk	020 8753 5646
Complaints	h&fintouch@lbhf.gov.uk	020 8753 2456
Disabled aids/adaptations ongoing cases	h&fadvice.care@lbhf.gov.uk	020 8753 5462
Referral adult over 18 Referral children		020 8753 4198 020 8753 6600
Electricity loss	www.ukpowernetworks.co.uk (identify your supplier)	0800 316 3105
Environmental health	Cleaner.greener@lbhf.gov.uk	020 8753 1100
Gas leak	Please contact Gas Emergency Services first then call the customer service centre	0800 111 999

Service	Email	Phone
Home buy	h&fhomebuy@lbhf.gov.uk	020 8753 6464
Leaseholder Services	Service.charges@lbhf.gov.uk	020 8753 4500 0800 840 4501
Parks maintenance and Playgrounds	Parks@lbhf.gov.uk	020 8753 1768
Pest control	environmentalprotection@lbhf.gov.uk	020 8753 1081
Refuse collection	Cleaner.greener@lbhf.gov.uk	020 8753 1100
Social services	H&fadvice.care@lbhf.gov.uk (adults) familyservices@lbhf.gov.uk (children)	020 8753 5456 020 8753 6600
Street cleaning and lighting	Cleaner.greener@lbhf.gov.uk	020 8753 1100
Water supply/sewerage	Phone your supplier (Thames Water)	0800 316 9800

Information

Index

A		F		L		Stairs:	24
Asbestos:	9, 14, 65, 78	Fences:	15, 76	Leaseholders:	2, 14, 15, 58	Steps:	47
B		Fire safety:	3, 73, 74	Lifts:	10, 76	System maintenance:	81
Basins:	8, 21	Fittings:	8, 9, 15, 28, 62	Lighting:	8, 10, 16, 36, 59, 61, 83	T	
Baths:	18	Floors:	23	Locks and latches:	27	Timber:	20, 29, 34, 65
Blocked flue:	72	Fly tipping:	6	Louvre glass:	32	Toilets:	20
C		G		P		Trees:	6
Carbon Monoxide:	3, 37, 72	Gardens:	16	Paving:	47	U	
Caretaking:	6, 82	Gas:	2, 3, 8, 40, 61, 71, 82	Permissions:	58	UPVC:	30, 35
Ceilings:	23	Gates:	48	Pest control:	2, 6	V	
Chargeable repairs:	2, 58	Get involved:	86	Picture finder:	2, 17, 18	Ventilation:	8, 12, 72
Completion times:	2, 59, 60	Glazing:	31, 32	Planned works:	2, 62	Vents:	32
Consultation:	58	Grounds:	6, 82	Playground equipment:	6	W	
Contacts:	3, 82	Gutters:	8	Property:	7, 9, 14, 59, 61, 62, 67, 77	Walls:	7
Contents:	2	H		R		Water:	8, 9, 11, 12, 13, 37, 38, 39, 41, 59, 61, 69, 77
Cupboards:	9, 12, 25	Handy-person:	2, 53	Repairs on defects:	2, 62	Windows:	33, 34, 35
Cyclical maintenance:	67	Hanging tiles:	47	Reporting a repair:	5	Y	
D		Heating:	8, 15, 16, 38, 39, 59, 61, 67, 71	Roofs:	7, 44	Your responsibility:	58, 78
Discretionary repairs:	18, 20, 21, 23, 25, 27, 28, 29, 31, 48, 49, 69	I		S			
Doors:	7, 27, 28	Identification:	2, 55, 56	Sash Window:	33, 34		
Drainage:	8, 46	Improvements:	3, 81	Security:	2, 9, 52, 55, 56, 73, 81		
E		Inspection:	32, 63, 69, 75	Sheltered residents:	2, 53		
Electrics:	15, 37, 67	Insurance:	64	Showers:	8, 11		
Emergency repairs:	2, 59, 61	Introduction:	2, 4	Sinks:	21		
Estate inspections:	3, 76	K		Sinks and basins:	21		
		Kitchen units:	60	Staff:	4, 17, 55, 76		



Repairs and Maintenance Handbook

GET INVOLVED

GET INVOLVED

We're committed to improving and we know the best way to do this is to work with you and ask you for your views.

The Resident Involvement team can help you to get involved and make a difference in many different ways. Contact us on **020 8753 6652** or **getinvolved@lbhf.gov.uk** to find out more.

Want to work with us to improve the repairs and maintenance service?

Find out more about our resident led Repairs Working Group and other ways to get involved at **www.lbhf.gov.uk/housing/resident-involvement**

Your views are important to us and we're listening, learning and improving as a result.

Ways to report a repair:

Freephone: 0800 023 4499

Email: Housing.Repairs@lbhf.gov.uk

Online: www.lbhf.gov.uk/housing/council-tenants/reporting-repairs/housing-repairs-notification-form

